

HP ProLiant ML110 G6 Server

Maintenance and Service Guide



Legal notices

© Copyright 2009, 2011 Hewlett-Packard Development Company, L.P.

The information contained herein is subject to change without notice. The only warranties for HP products and services are set forth in the express warranty statements accompanying such products and services. Nothing herein should be construed as constituting an additional warranty. HP shall not be liable for technical or editorial errors or omissions contained herein.

Intel, Intel Xeon, Intel Celeron, Intel Pentium, and Intel Core are trademarks of Intel Corporation in the U.S. and other countries.

Microsoft and Windows Server are U.S. registered trademarks of Microsoft Corporation.

Contents

Customer Self Repair	5
Parts only warranty service	5
Illustrated parts catalog	16
Mechanical components	16
System components	20
HP contact information	26
Before you contact HP	26
Removal and replacement procedures	27
Required tools	27
Server warnings and cautions	27
Symbols on equipment	28
Electrostatic discharge information	29
Pre-installation procedure	29
Post-installation procedure	30
Powering down the server	30
Cable management	31
System covers	32
Access panel	32
Front bezel	33
Drive bay configuration	34
System drive cable management	35
Removable media drives	37
Hard drives	40
System board configuration	44
Processor	44
Memory	54
Expansion board	56
Flash-backed write cache procedures	61
Flash-backed write cache module	61
Flash-backed write cache capacitor pack	64
System battery	66
System battery replacement warnings	66
System fan	69
Power supply unit	71
Diagnostics tools	73
Troubleshooting resources	73
HP Insight Diagnostics	73
Survey Utility	74
Array Diagnostic Utility	74
HP Instant Support Enterprise Edition	74
Web-Based Enterprise Service	74
Open Services Event Manager	75
Phoenix SecureCore BIOS software	75
Configuring the system BIOS	75
Setup Utility navigation keys	77
Setup Utility menus	78

BIOS splash screen	97
Recording custom Setup values.....	98
Loading system defaults	98
Clearing CMOS	99
Recovering BIOS.....	99
Flashing the system BIOS	100
Power-On-Self-Test.....	101
Connectors, switches, and LEDs	104
Connectors and components	104
Front panel.....	104
Rear panel	105
System board	106
System configuration switch	108
Status LED indicators	109
External LED indicators	109
System board LED indicators	110
System specifications	111
Hardware specifications	111
System unit.....	111
Memory	112
Processor	112
Power supply unit.....	113
Software specifications	114
Physical specifications	115
Environmental specifications.....	115
Index.....	116

Customer Self Repair

HP products are designed with many Customer Self Repair (CSR) parts to minimize repair time and allow for greater flexibility in performing defective parts replacement. If during the diagnosis period HP (or HP service providers or service partners) identifies that the repair can be accomplished by the use of a CSR part, HP will ship that part directly to you for replacement. There are two categories of CSR parts:

- **Mandatory**—Parts for which customer self repair is mandatory. If, however, you require that HP replace them for you, there may or may not be additional charges, depending on the type of warranty service designated for your product.
- **Optional**—Parts for which customer self repair is optional. These parts are also designed for customer self repair. If, however, you require that HP replace them for you, there may or may not be additional charges, depending on the type of warranty service designated for your product.

NOTE: Some HP parts are not designed for customer self repair. In order to satisfy the customer warranty, HP requires that an authorized service provider replace the part. These parts are identified as "No" in the Illustrated Parts Catalog.

Based on availability and where geography permits, CSR parts will be shipped for next business day delivery. Same day or four-hour delivery may be offered at an additional charge where geography permits. If assistance is required, you can call the HP Technical Support Center and a technician will help you over the telephone. HP specifies in the materials shipped with a replacement CSR part whether a defective part must be returned to HP. In cases where it is required to return the defective part to HP, you must ship the defective part back to HP within a defined period of time, normally five (5) business days. The defective part must be returned with the associated documentation in the provided shipping material. Failure to return the defective part may result in HP billing you for the replacement. With a customer self repair, HP will pay all shipping and part return costs and determine the courier/carrier to be used.

For more information about HP's Customer Self Repair program, contact your local service provider. For the North American program, refer to the HP website (<http://www.hp.com/go/selfrepair>).

Parts only warranty service

Your HP Limited Warranty may include a parts only warranty service. Under the terms of parts only warranty service, HP will provide replacement parts free of charge.

For parts only warranty service, CSR part replacement is mandatory. If you request HP to replace these parts, you will be charged for the travel and labor costs of this service.

Réparation par le client (CSR)

Les produits HP comportent de nombreuses pièces CSR (Customer Self Repair = réparation par le client) afin de minimiser les délais de réparation et faciliter le remplacement des pièces défectueuses. Si pendant la période de diagnostic, HP (ou ses partenaires ou mainteneurs agréés) détermine que la réparation peut être effectuée à l'aide d'une pièce CSR, HP vous l'envoie directement. Il existe deux catégories de pièces CSR:

- **Obligatoire**—Pièces pour lesquelles la réparation par le client est obligatoire. Si vous demandez à HP de remplacer ces pièces, les coûts de déplacement et main d'œuvre du service vous seront facturés.
- **Facultatif**—Pièces pour lesquelles la réparation par le client est facultative. Ces pièces sont également conçues pour permettre au client d'effectuer lui-même la réparation. Toutefois, si vous demandez à HP de remplacer ces pièces, l'intervention peut ou non vous être facturée, selon le type de garantie applicable à votre produit.

REMARQUE: Certaines pièces HP ne sont pas conçues pour permettre au client d'effectuer lui-même la réparation. Pour que la garantie puisse s'appliquer, HP exige que le remplacement de la pièce soit effectué par un Mainteneur Agréé. Ces pièces sont identifiées par la mention "Non" dans le Catalogue illustré.

Les pièces CSR sont livrées le jour ouvré suivant, dans la limite des stocks disponibles et selon votre situation géographique. Si votre situation géographique le permet et que vous demandez une livraison le jour même ou dans les 4 heures, celle-ci vous sera facturée. Pour bénéficier d'une assistance téléphonique, appelez le Centre d'assistance technique HP. Dans les documents envoyés avec la pièce de rechange CSR, HP précise s'il est nécessaire de lui retourner la pièce défectueuse. Si c'est le cas, vous devez le faire dans le délai indiqué, généralement cinq (5) jours ouvrés. La pièce et sa documentation doivent être retournées dans l'emballage fourni. Si vous ne retournez pas la pièce défectueuse, HP se réserve le droit de vous facturer les coûts de remplacement. Dans le cas d'une pièce CSR, HP supporte l'ensemble des frais d'expédition et de retour, et détermine la société de courses ou le transporteur à utiliser.

Pour plus d'informations sur le programme CSR de HP, contactez votre Mainteneur Agréé local. Pour plus d'informations sur ce programme en Amérique du Nord, consultez le site Web HP (<http://www.hp.com/go/selfrepair>).

Service de garantie "pièces seules"

Votre garantie limitée HP peut inclure un service de garantie "pièces seules". Dans ce cas, les pièces de rechange fournies par HP ne sont pas facturées.

Dans le cadre de ce service, la réparation des pièces CSR par le client est obligatoire. Si vous demandez à HP de remplacer ces pièces, les coûts de déplacement et main d'œuvre du service vous seront facturés.

Riparazione da parte del cliente

Per abbreviare i tempi di riparazione e garantire una maggiore flessibilità nella sostituzione di parti difettose, i prodotti HP sono realizzati con numerosi componenti che possono essere riparati direttamente dal cliente (CSR, Customer Self Repair). Se in fase di diagnostica HP (o un centro di servizi o di assistenza HP) identifica il guasto come riparabile mediante un ricambio CSR, HP lo spedisce direttamente al cliente per la sostituzione. Vi sono due categorie di parti CSR:

- **Obbligatorie**—Parti che devono essere necessariamente riparate dal cliente. Se il cliente ne affida la riparazione ad HP, deve sostenere le spese di spedizione e di manodopera per il servizio.
- **Opzionali**—Parti la cui riparazione da parte del cliente è facoltativa. Si tratta comunque di componenti progettati per questo scopo. Se tuttavia il cliente ne richiede la sostituzione ad HP, potrebbe dover sostenere spese aggiuntive a seconda del tipo di garanzia previsto per il prodotto.

NOTA: Alcuni componenti HP non sono progettati per la riparazione da parte del cliente. Per rispettare la garanzia, HP richiede che queste parti siano sostituite da un centro di assistenza autorizzato. Tali parti sono identificate da un "No" nel Catalogo illustrato dei componenti.

In base alla disponibilità e alla località geografica, le parti CSR vengono spedite con consegna entro il giorno lavorativo seguente. La consegna nel giorno stesso o entro quattro ore è offerta con un supplemento di costo solo in alcune zone. In caso di necessità si può richiedere l'assistenza telefonica di un addetto del centro di supporto tecnico HP. Nel materiale fornito con una parte di ricambio CSR, HP specifica se il cliente deve restituire dei componenti. Qualora sia richiesta la resa ad HP del componente difettoso, lo si deve spedire ad HP entro un determinato periodo di tempo, generalmente cinque (5) giorni lavorativi. Il componente difettoso deve essere restituito con la documentazione associata nell'imballo di spedizione fornito. La mancata restituzione del componente può comportare la fatturazione del ricambio da parte di HP. Nel caso di riparazione da parte del cliente, HP sostiene tutte le spese di spedizione e resa e sceglie il corriere/vettore da utilizzare.

Per ulteriori informazioni sul programma CSR di HP contattare il centro di assistenza di zona. Per il programma in Nord America fare riferimento al sito Web HP (<http://www.hp.com/go/selfrepair>).

Servizio di garanzia per i soli componenti

La garanzia limitata HP può includere un servizio di garanzia per i soli componenti. Nei termini di garanzia del servizio per i soli componenti, HP fornirà gratuitamente le parti di ricambio.

Per il servizio di garanzia per i soli componenti è obbligatoria la formula CSR che prevede la riparazione da parte del cliente. Se il cliente invece richiede la sostituzione ad HP, dovrà sostenere le spese di spedizione e di manodopera per il servizio.

Customer Self Repair

HP Produkte enthalten viele CSR-Teile (Customer Self Repair), um Reparaturzeiten zu minimieren und höhere Flexibilität beim Austausch defekter Bauteile zu ermöglichen. Wenn HP (oder ein HP Servicepartner) bei der Diagnose feststellt, dass das Produkt mithilfe eines CSR-Teils repariert werden kann, sendet Ihnen HP dieses Bauteil zum Austausch direkt zu. CSR-Teile werden in zwei Kategorien unterteilt:

- **Zwingend**—Teile, für die das Customer Self Repair-Verfahren zwingend vorgegeben ist. Wenn Sie den Austausch dieser Teile von HP vornehmen lassen, werden Ihnen die Anfahrt- und Arbeitskosten für diesen Service berechnet.
- **Optional**—Teile, für die das Customer Self Repair-Verfahren optional ist. Diese Teile sind auch für Customer Self Repair ausgelegt. Wenn Sie jedoch den Austausch dieser Teile von HP vornehmen lassen möchten, können bei diesem Service je nach den für Ihr Produkt vorgesehenen Garantiebedingungen zusätzliche Kosten anfallen.

HINWEIS: Einige Teile sind nicht für Customer Self Repair ausgelegt. Um den Garantieanspruch des Kunden zu erfüllen, muss das Teil von einem HP Servicepartner ersetzt werden. Im illustrierten Teilekatalog sind diese Teile mit „No“ bzw. „Nein“ gekennzeichnet.

CSR-Teile werden abhängig von der Verfügbarkeit und vom Lieferziel am folgenden Geschäftstag geliefert. Für bestimmte Standorte ist eine Lieferung am selben Tag oder innerhalb von vier Stunden gegen einen Aufpreis verfügbar. Wenn Sie Hilfe benötigen, können Sie das HP technische Support Center anrufen und sich von einem Mitarbeiter per Telefon helfen lassen. Den Materialien, die mit einem CSR-Ersatzteil geliefert werden, können Sie entnehmen, ob das defekte Teil an HP zurückgeschickt werden muss. Wenn es erforderlich ist, das defekte Teil an HP zurückzuschicken, müssen Sie dies innerhalb eines vorgegebenen Zeitraums tun, in der Regel innerhalb von fünf (5) Geschäftstagen. Das defekte Teil muss mit der zugehörigen Dokumentation in der Verpackung zurückgeschickt werden, die im Lieferumfang enthalten ist. Wenn Sie das defekte Teil nicht zurückschicken, kann HP Ihnen das Ersatzteil in Rechnung stellen. Im Falle von Customer Self Repair kommt HP für alle Kosten für die Lieferung und Rücksendung auf und bestimmt den Kurier-/Frachtdienst.

Weitere Informationen über das HP Customer Self Repair Programm erhalten Sie von Ihrem Servicepartner vor Ort. Informationen über das CSR-Programm in Nordamerika finden Sie auf der HP Website unter (<http://www.hp.com/go/selfrepair>).

Parts-only Warranty Service (Garantieservice ausschließlich für Teile)

Ihre HP Garantie umfasst möglicherweise einen Parts-only Warranty Service (Garantieservice ausschließlich für Teile). Gemäß den Bestimmungen des Parts-only Warranty Service stellt HP Ersatzteile kostenlos zur Verfügung.

Für den Parts-only Warranty Service ist das CSR-Verfahren zwingend vorgegeben. Wenn Sie den Austausch dieser Teile von HP vornehmen lassen, werden Ihnen die Anfahrt- und Arbeitskosten für diesen Service berechnet.

Reparaciones del propio cliente

Los productos de HP incluyen muchos componentes que el propio usuario puede reemplazar (*Customer Self Repair*, CSR) para minimizar el tiempo de reparación y ofrecer una mayor flexibilidad a la hora de realizar sustituciones de componentes defectuosos. Si, durante la fase de diagnóstico, HP (o los proveedores o socios de servicio de HP) identifica que una reparación puede llevarse a cabo mediante el uso de un componente CSR, HP le enviará dicho componente directamente para que realice su sustitución. Los componentes CSR se clasifican en dos categorías:

- **Obligatorio**—Componentes para los que la reparación por parte del usuario es obligatoria. Si solicita a HP que realice la sustitución de estos componentes, tendrá que hacerse cargo de los gastos de desplazamiento y de mano de obra de dicho servicio.
- **Opcional**—Componentes para los que la reparación por parte del usuario es opcional. Estos componentes también están diseñados para que puedan ser reparados por el usuario. Sin embargo, si precisa que HP realice su sustitución, puede o no conllevar costes adicionales, dependiendo del tipo de servicio de garantía correspondiente al producto.

NOTA: Algunos componentes no están diseñados para que puedan ser reparados por el usuario. Para que el usuario haga valer su garantía, HP pone como condición que un proveedor de servicios autorizado realice la sustitución de estos componentes. Dichos componentes se identifican con la palabra "No" en el catálogo ilustrado de componentes.

Según la disponibilidad y la situación geográfica, los componentes CSR se enviarán para que lleguen a su destino al siguiente día laborable. Si la situación geográfica lo permite, se puede solicitar la entrega en el mismo día o en cuatro horas con un coste adicional. Si precisa asistencia técnica, puede llamar al Centro de asistencia técnica de HP y recibirá ayuda telefónica por parte de un técnico. Con el envío de materiales para la sustitución de componentes CSR, HP especificará si los componentes defectuosos deberán devolverse a HP. En aquellos casos en los que sea necesario devolver algún componente a HP, deberá hacerlo en el periodo de tiempo especificado, normalmente cinco días laborables. Los componentes defectuosos deberán devolverse con toda la documentación relacionada y con el embalaje de envío. Si no enviara el componente defectuoso requerido, HP podrá cobrarle por el de sustitución. En el caso de todas sustituciones que lleve a cabo el cliente, HP se hará cargo de todos los gastos de envío y devolución de componentes y escogerá la empresa de transporte que se utilice para dicho servicio.

Para obtener más información acerca del programa de Reparaciones del propio cliente de HP, póngase en contacto con su proveedor de servicios local. Si está interesado en el programa para Norteamérica, visite la página web de HP siguiente (<http://www.hp.com/go/selfrepair>).

Servicio de garantía exclusivo de componentes

La garantía limitada de HP puede que incluya un servicio de garantía exclusivo de componentes. Según las condiciones de este servicio exclusivo de componentes, HP le facilitará los componentes de repuesto sin cargo adicional alguno.

Para este servicio de garantía exclusivo de componentes, es obligatoria la sustitución de componentes por parte del usuario (CSR). Si solicita a HP que realice la sustitución de estos componentes, tendrá que hacerse cargo de los gastos de desplazamiento y de mano de obra de dicho servicio.

Customer Self Repair

Veel onderdelen in HP producten zijn door de klant zelf te repareren, waardoor de reparatieduur tot een minimum beperkt kan blijven en de flexibiliteit in het vervangen van defecte onderdelen groter is. Deze onderdelen worden CSR-onderdelen (Customer Self Repair) genoemd. Als HP (of een HP Service Partner) bij de diagnose vaststelt dat de reparatie kan worden uitgevoerd met een CSR-onderdeel, verzendt HP dat onderdeel rechtstreeks naar u, zodat u het defecte onderdeel daarmee kunt vervangen. Er zijn twee categorieën CSR-onderdelen:

- **Verplicht**—Onderdelen waarvoor reparatie door de klant verplicht is. Als u HP verzoekt deze onderdelen voor u te vervangen, worden u voor deze service reiskosten en arbeidsloon in rekening gebracht.
- **Optioneel**—Onderdelen waarvoor reparatie door de klant optioneel is. Ook deze onderdelen zijn ontworpen voor reparatie door de klant. Als u echter HP verzoekt deze onderdelen voor u te vervangen, kunnen daarvoor extra kosten in rekening worden gebracht, afhankelijk van het type garantieservice voor het product.

OPMERKING: Sommige HP onderdelen zijn niet ontwikkeld voor reparatie door de klant. In verband met de garantievoorwaarden moet het onderdeel door een geautoriseerde Service Partner worden vervangen. Deze onderdelen worden in de geïllustreerde onderdelencatalogus aangemerkt met "Nee".

Afhankelijk van de leverbaarheid en de locatie worden CSR-onderdelen verzonden voor levering op de eerstvolgende werkdag. Levering op dezelfde dag of binnen vier uur kan tegen meerkosten worden aangeboden, indien dit mogelijk is gezien de locatie. Indien assistentie gewenst is, belt u een HP Service Partner om via de telefoon technische ondersteuning te ontvangen. HP vermeldt in de documentatie bij het vervangende CSR-onderdeel of het defecte onderdeel aan HP moet worden geretourneerd. Als het defecte onderdeel aan HP moet worden teruggezonden, moet u het defecte onderdeel binnen een bepaalde periode, gewoonlijk vijf (5) werkdagen, retourneren aan HP. Het defecte onderdeel moet met de bijbehorende documentatie worden geretourneerd in het meegeleverde verpakkingsmateriaal. Als u het defecte onderdeel niet terugzendt, kan HP u voor het vervangende onderdeel kosten in rekening brengen. Bij reparatie door de klant betaalt HP alle verzendkosten voor het vervangende en geretourneerde onderdeel en kiest HP zelf welke koerier/transportonderneming hiervoor wordt gebruikt.

Neem contact op met een Service Partner voor meer informatie over het Customer Self Repair programma van HP. Informatie over Service Partners vindt u op de HP website (<http://www.hp.com/go/selfrepair>).

Garantieservice "Parts Only"

Het is mogelijk dat de HP garantie alleen de garantieservice "Parts Only" omvat. Volgens de bepalingen van de Parts Only garantieservice zal HP kosteloos vervangende onderdelen ter beschikking stellen.

Voor de Parts Only garantieservice is vervanging door CSR-onderdelen verplicht. Als u HP verzoekt deze onderdelen voor u te vervangen, worden u voor deze service reiskosten en arbeidsloon in rekening gebracht.

Reparo feito pelo cliente

Os produtos da HP são projetados com muitas peças para reparo feito pelo cliente (CSR) de modo a minimizar o tempo de reparo e permitir maior flexibilidade na substituição de peças com defeito. Se, durante o período de diagnóstico, a HP (ou fornecedores/parceiros de serviço da HP) concluir que o reparo pode ser efetuado pelo uso de uma peça CSR, a peça de reposição será enviada diretamente ao cliente. Existem duas categorias de peças CSR:

- **Obrigatória**—Peças cujo reparo feito pelo cliente é obrigatório. Se desejar que a HP substitua essas peças, serão cobradas as despesas de transporte e mão-de-obra do serviço.
- **Opcional**—Peças cujo reparo feito pelo cliente é opcional. Essas peças também são projetadas para o reparo feito pelo cliente. No entanto, se desejar que a HP as substitua, pode haver ou não a cobrança de taxa adicional, dependendo do tipo de serviço de garantia destinado ao produto.

OBSERVAÇÃO: Algumas peças da HP não são projetadas para o reparo feito pelo cliente. A fim de cumprir a garantia do cliente, a HP exige que um técnico autorizado substitua a peça. Essas peças estão identificadas com a marca "No" (Não), no catálogo de peças ilustrado.

Conforme a disponibilidade e o local geográfico, as peças CSR serão enviadas no primeiro dia útil após o pedido. Onde as condições geográficas permitirem, a entrega no mesmo dia ou em quatro horas pode ser feita mediante uma taxa adicional. Se precisar de auxílio, entre em contato com o Centro de suporte técnico da HP para que um técnico o ajude por telefone. A HP especifica nos materiais fornecidos com a peça CSR de reposição se a peça com defeito deve ser devolvida à HP. Nos casos em que isso for necessário, é preciso enviar a peça com defeito à HP dentro do período determinado, normalmente cinco (5) dias úteis. A peça com defeito deve ser enviada com a documentação correspondente no material de transporte fornecido. Caso não o faça, a HP poderá cobrar a reposição. Para as peças de reparo feito pelo cliente, a HP paga todas as despesas de transporte e de devolução da peça e determina a transportadora/serviço postal a ser utilizado.

Para obter mais informações sobre o programa de reparo feito pelo cliente da HP, entre em contato com o fornecedor de serviços local. Para o programa norte-americano, visite o site da HP (<http://www.hp.com/go/selfrepair>).

Serviço de garantia apenas para peças

A garantia limitada da HP pode incluir um serviço de garantia apenas para peças. Segundo os termos do serviço de garantia apenas para peças, a HP fornece as peças de reposição sem cobrar nenhuma taxa.

No caso desse serviço, a substituição de peças CSR é obrigatória. Se desejar que a HP substitua essas peças, serão cobradas as despesas de transporte e mão-de-obra do serviço.

顧客自己修理保証サービス

修理時間を短縮し、故障部品の交換における高い柔軟性を確保するために、HP製品には多数の顧客自己修理（CSR）部品があります。診断の際に、CSR部品を使用すれば修理ができるとHP（HPまたはHP正規保守代理店）が判断した場合、HPはその部品を直接、お客様に発送し、お客様に交換していただきます。CSR部品には以下の2通りがあります。

- 必須 - 顧客自己修理が必須の部品。当該部品について、もしもお客様がHPに交換作業を依頼される場合には、その修理サービスに関する交通費および人件費がお客様に請求されます。
- 任意 - 顧客自己修理が任意である部品。この部品も顧客自己修理用です。当該部品について、もしもお客様がHPに交換作業を依頼される場合には、お買い上げの製品に適用される保証サービス内容の範囲内においては、別途費用を負担していただくことなく保証サービスを受けることができます。

注：HP製品の一部の部品は、顧客自己修理用ではありません。製品の保証を継続するためには、HPまたはHP正規保守代理店による交換作業が必須となります。部品カタログには、当該部品が顧客自己修理除外品である旨が記載されています。

部品供給が可能な場合、地域によっては、CSR部品を翌営業日に届くように発送します。また、地域によっては、追加費用を負担いただくことにより同日または4時間以内に届くように発送することも可能な場合があります。サポートが必要なときは、HPの修理受付窓口に電話していただければ、技術者が電話でアドバイスします。交換用のCSR部品または同梱物には、故障部品をHPに返送する必要があるかどうかが表示されています。故障部品をHPに返送する必要がある場合は、指定期限内（通常は5営業日以内）に故障部品をHPに返送してください。故障部品を返送する場合は、届いた時の梱包箱に関連書類とともに入れてください。故障部品を返送しない場合、HPから部品費用が請求されます。顧客自己修理の際には、HPは送料および部品返送費を全額負担し、使用する宅配便会社や運送会社を指定します。

部品のみ保証サービス

HP保証サービスには、部品のみ保証サービスが適用される場合があります。このサービスでは、交換部品は無償で提供されます。

部品のみ保証サービスにおいては、CSR部品をお客様により交換作業していただくことが必須となります。当該部品について、もしもお客様がHPに交換作業を依頼される場合には、その修理サービスに関する交通費および人件費はお客様の負担となります。

客户自行维修

HP 产品提供许多客户自行维修 (CSR) 部件，以尽可能缩短维修时间和在更换缺陷部件方面提供更大的灵活性。如果在诊断期间 HP（或 HP 服务提供商或服务合作伙伴）确定可以通过使用 CSR 部件完成维修，HP 将直接把该部件发送给您进行更换。有两类 CSR 部件：

- **强制性的** — 要求客户必须自行维修的部件。如果您请求 HP 更换这些部件，则必须为该服务支付差旅费和人工费用。
- **可选的** — 客户可以选择是否自行维修的部件。这些部件也是为客户自行维修设计的。不过，如果您要求 HP 为您更换这些部件，则根据为您的产品指定的保修服务类型，HP 可能收取或不再收取任何附加费用。

注：某些 HP 部件的设计并未考虑客户自行维修。为了满足客户保修的需要，HP 要求授权服务提供商更换相关部件。这些部件在部件图解目录中标记为“否”。

CSR 部件将在下一个工作日发运（取决于备货情况和允许的地理范围）。在允许的地理范围内，可在当天或四小时内发运，但要收取额外费用。如果需要帮助，您可以致电 HP 技术支持中心，将会有技术人员通过电话为您提供帮助。HP 会在随更换的 CSR 部件发运的材料中指明是否必须将有缺陷的部件返还给 HP。如果要求您将有缺陷的部件返还给 HP，那么您必须在规定期限内（通常是五 (5) 个工作日）将缺陷部件发给 HP。有缺陷的部件必须随所提供的发运材料中的相关文件一起返还。如果未能送还有缺陷的部件，HP 可能会要求您支付更换费用。客户自行维修时，HP 将承担所有相关运输和部件返回费用，并指定快递商/承运商。

有关 HP 客户自行维修计划的详细信息，请与您当地的服务提供商联系。有关北美地区的计划，请访问 HP 网站 (<http://www.hp.com/go/selfrepair>)。

仅部件保修服务

您的 HP 有限保修服务可能涉及仅部件保修服务。根据仅部件保修服务条款的规定，HP 将免费提供更换的部件。

仅部件保修服务要求进行 CSR 部件更换。如果您请求 HP 更换这些部件，则必须为该服务支付差旅费和人工费用。

客戶自行維修

HP 產品設計了許多「客戶自行維修」(CSR) 的零件以減少維修時間，並且使得更換瑕疵零件時能有更大的彈性。如果在診斷期間 HP (或 HP 服務供應商或維修夥伴) 辨認出此項維修工作可以藉由使用 CSR 零件來完成，則 HP 將直接寄送該零件給您作更換。CSR 零件分為兩種類別：

- **強制的** — 客戶自行維修所使用的零件是強制性的。如果您要求 HP 更換這些零件，HP 將會向您收取此服務所需的外出費用與勞動成本。
- **選購的** — 客戶自行維修所使用的零件是選購的。這些零件也設計用於客戶自行維修之用。不過，如果您要求 HP 為您更換，則可能需要也可能不需要負擔額外的費用，端視針對此產品指定的保固服務類型而定。

備註：某些 HP 零件沒有消費者可自行維修的設計。為符合客戶保固，HP 需要授權的服務供應商更換零件。這些零件在圖示的零件目錄中，被標示為「否」。

基於材料取得及環境允許的情況下，CSR 零件將於下一個工作日以快遞寄送。在環境的允許下當天或四小時內送達，則可能需要額外的費用。若您需要協助，可致電「HP 技術支援中心」，會有一位技術人員透過電話來協助您。不論損壞的零件是否必須退回，HP 皆會在與 CSR 替換零件一起運送的材料中註明。若要將損壞的零件退回 HP，您必須在指定的一段時間內（通常為五 (5) 個工作天），將損壞的零件寄回 HP。損壞的零件必須與寄送資料中隨附的相關技術文件一併退還。如果無法退還損壞的零件，HP 可能要向您收取替換費用。針對客戶自行維修情形，HP 將負責所有運費及零件退還費用並指定使用何家快遞/貨運公司。

如需 HP 的「客戶自行維修」方案詳細資訊，請連絡您當地的服務供應商。至於北美方案，請參閱 HP 網站 (<http://www.hp.com/go/selfrepair>)。

僅限零件的保固服務

您的「HP 有限保固」可能包含僅限零件的保固服務。在僅限零件的保固服務情況下，HP 將免費提供替換零件。

針對僅限零件的保固服務，CSR 零件替換是強制性的。如果您要求 HP 更換這些零件，HP 將會向您收取此服務所需的外出費用與勞動成本。

고객 셀프 수리

HP 제품은 수리 시간을 최소화하고 결함이 있는 부품 교체 시 더욱 융통성을 발휘할 수 있도록 하기 위해 고객 셀프 수리(CSR) 부품을 다량 사용하여 설계되었습니다. 진단 기간 동안 HP(또는 HP 서비스 공급업체 또는 서비스 협력업체)에서 CSR 부품을 사용하여 수리가 가능하다고 판단되면 HP는 해당 부품을 바로 사용자에게 보내어 사용자가 교체할 수 있도록 합니다. CSR 부품에는 두 가지 종류가 있습니다.

- **고객 셀프 수리가 의무 사항인 필수 부품.** 사용자가 HP에 이 부품의 교체를 요청할 경우 이 서비스에 대한 출장비 및 작업비가 청구됩니다.
- **고객 셀프 수리가 선택 사항인 부품.** 이 부품들도 고객 셀프 수리가 가능하도록 설계되었습니다. 하지만 사용자가 HP에 이 부품의 교체를 요청할 경우 사용자가 구입한 제품에 해당하는 보증 서비스 유형에 따라 추가 비용 없이 교체가 가능할 수 있습니다.

참고: 일부 HP 부품은 고객 셀프 수리가 불가능하도록 설계되었습니다. HP는 만족스러운 고객 보증을 위해 공인 서비스 제공업체를 통해 부품을 교체하도록 하고 있습니다. 이러한 부품들은 Illustrated Parts Catalog에 "No"라고 표시되어 있습니다.

CSR 부품은 재고 상태와 지리적 조건이 허용하는 경우 다음 영업일 납품이 가능하도록 배송이 이루어집니다. 지리적 조건이 허용하는 경우 추가 비용이 청구되는 조건으로 당일 또는 4시간 배송이 가능할 수도 있습니다. 도움이 필요하시면 HP 기술 지원 센터로 전화하십시오. 전문 기술자가 전화로 도움을 줄 것입니다. HP는 결함이 발생한 부품을 HP로 반환해야 하는지 여부를 CSR 교체 부품과 함께 배송된 자료에 지정합니다. 결함이 발생한 부품을 HP로 반환해야 하는 경우에는 지정된 기간 내(통상 영업일 기준 5일)에 HP로 반환해야 합니다. 이 때 결함이 발생한 부품은 제공된 포장 재료에 넣어 관련 설명서와 함께 반환해야 합니다. 결함이 발생한 부품을 반환하지 않는 경우 HP가 교체 부품에 대해 비용을 청구할 수 있습니다. 고객 셀프 수리의 경우, HP는 모든 운송 및 부품 반환 비용을 부담하며 이용할 운송업체 및 택배 서비스를 결정합니다.

HP 고객 셀프 수리 프로그램에 대한 자세한 내용은 가까운 서비스 제공업체에 문의하십시오. 북미 지역의 프로그램에 대해서는 HP 웹 사이트(<http://www.hp.com/go/selfrepair>)를 참조하십시오.

부품 제공 보증 서비스

HP 제한 보증에는 부품 제공 보증 서비스가 포함될 수 있습니다. 이러한 경우 HP는 부품 제공 보증 서비스의 조건에 따라 교체 부품만을 무료로 제공합니다.

부품 제공 보증 서비스 제공 시 CSR 부품 교체는 의무 사항입니다. 사용자가 HP에 이 부품의 교체를 요청할 경우 이 서비스에 대한 출장비 및 작업비가 청구됩니다.

Illustrated parts catalog

Mechanical components

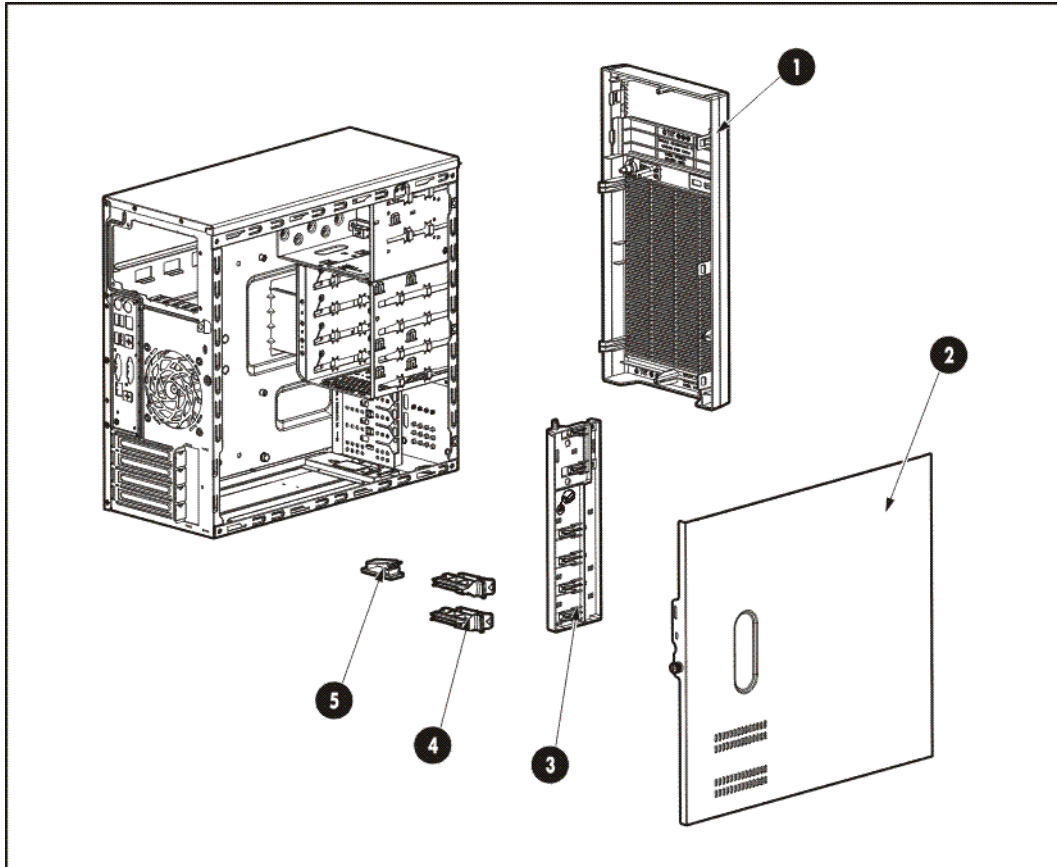

Item	Description	Spare part number	Customer self repair (see page 5)
1	Front bezel	584249-001	Mandatory ¹
2	Access panel	584246-001	Mandatory ¹
	Miscellaneous plastic kit	585180-001	Mandatory ¹
3	Drive release latch	—	—
4	Full-length card retainer	—	—
5	Cable clamp	—	—

¹Mandatory—Parts for which customer self repair is mandatory. If, however, you require that HP replace them for you, there may or may not be additional charges, depending on the type of warranty service designated for your product.

²Optional—Parts for which customer self repair is optional. These parts are also designed for customer self repair. If, however, you require that HP replace them for you, there may or may not be additional charges, depending on the type of warranty service designated for your product.

³No—Some HP parts are not designed for customer self repair. In order to satisfy the customer warranty, HP requires that an authorized service provider replace the part. These parts are identified as "No" in the Illustrated Parts Catalog.

¹Mandatory: Obligatoire—Pièces pour lesquelles la réparation par le client est obligatoire. Si vous demandez à HP de remplacer ces pièces, les coûts de déplacement et main d'œuvre du service vous seront facturés.

²Optional: Facultatif—Pièces pour lesquelles la réparation par le client est facultative. Ces pièces sont également conçues pour permettre au client d'effectuer lui-même la réparation. Toutefois, si vous demandez à HP de remplacer ces pièces, l'intervention peut ou non vous être facturée, selon le type de garantie applicable à votre produit.

³No: Non—Certaines pièces HP ne sont pas conçues pour permettre au client d'effectuer lui-même la réparation. Pour que la garantie puisse s'appliquer, HP exige que le remplacement de la pièce soit effectué par un Mainteneur Agréé. Ces pièces sont identifiées par la mention "Non" dans le Catalogue illustré.

¹Mandatory: Obbligatorie—Parti che devono essere necessariamente riparate dal cliente. Se il cliente ne affida la riparazione ad HP, deve sostenere le spese di spedizione e di manodopera per il servizio.

²Optional: Opzionali—Parti la cui riparazione da parte del cliente è facoltativa. Si tratta comunque di componenti progettati per questo scopo. Se tuttavia il cliente ne richiede la sostituzione ad HP, potrebbe dover sostenere spese addizionali a seconda del tipo di garanzia previsto per il prodotto.

³No: Non CSR—Alcuni componenti HP non sono progettati per la riparazione da parte del cliente. Per rispettare la garanzia, HP richiede che queste parti siano sostituite da un centro di assistenza autorizzato. Tali parti sono identificate da un "No" nel Catalogo illustrato dei componenti.

¹Mandatory: Zwingend—Teile, die im Rahmen des Customer Self Repair Programms ersetzt werden müssen. Wenn Sie diese Teile von HP ersetzen lassen, werden Ihnen die Versand- und Arbeitskosten für diesen Service berechnet.

²Optional: Optional—Teile, für die das Customer Self Repair-Verfahren optional ist. Diese Teile sind auch für Customer Self Repair ausgelegt. Wenn Sie jedoch den Austausch dieser Teile von HP vornehmen lassen möchten, können bei diesem Service je nach den für Ihr Produkt vorgesehenen Garantiebedingungen zusätzliche Kosten anfallen.

³No: Kein—Einige Teile sind nicht für Customer Self Repair ausgelegt. Um den Garantieanspruch des Kunden zu erfüllen, muss das Teil von einem HP Servicepartner ersetzt werden. Im illustrierten Teilekatalog sind diese Teile mit „No“ bzw. „Nein“ gekennzeichnet.

¹Mandatory: Obligatorio—componentes para los que la reparación por parte del usuario es obligatoria. Si solicita a HP que realice la sustitución de estos componentes, tendrá que hacerse cargo de los gastos de desplazamiento y de mano de obra de dicho servicio.

²Optional: Opcional— componentes para los que la reparación por parte del usuario es opcional. Estos componentes también están diseñados para que puedan ser reparados por el usuario. Sin embargo, si precisa que HP realice su sustitución, puede o no conllevar costes adicionales, dependiendo del tipo de servicio de garantía correspondiente al producto.

³No: No—Algunos componentes no están diseñados para que puedan ser reparados por el usuario. Para que el usuario haga valer su garantía, HP pone como condición que un proveedor de servicios autorizado realice la sustitución de estos componentes. Dichos componentes se identifican con la palabra “No” en el catálogo ilustrado de componentes.

¹Mandatory: Verplicht—Onderdelen waarvoor Customer Self Repair verplicht is. Als u HP verzoekt deze onderdelen te vervangen, komen de reiskosten en het arbeidsloon voor uw rekening.

²Optional: Optioneel—Onderdelen waarvoor reparatie door de klant optioneel is. Ook deze onderdelen zijn ontworpen voor reparatie door de klant. Als u echter HP verzoekt deze onderdelen voor u te vervangen, kunnen daarvoor extra kosten in rekening worden gebracht, afhankelijk van het type garantieservice voor het product.

³No: Nee—Sommige HP onderdelen zijn niet ontwikkeld voor reparatie door de klant. In verband met de garantievoorwaarden moet het onderdeel door een geautoriseerde Service Partner worden vervangen. Deze onderdelen worden in de geïllustreerde onderdelencatalogus aangemerkt met “Nee”.

¹Mandatory: Obrigatória—Peças cujo reparo feito pelo cliente é obrigatório. Se desejar que a HP substitua essas peças, serão cobradas as despesas de transporte e mão-de-obra do serviço.

²Optional: Opcional—Peças cujo reparo feito pelo cliente é opcional. Essas peças também são projetadas para o reparo feito pelo cliente. No entanto, se desejar que a HP as substitua, pode haver ou não a cobrança de taxa adicional, dependendo do tipo de serviço de garantia destinado ao produto.

³No: Nenhuma—Algumas peças da HP não são projetadas para o reparo feito pelo cliente. A fim de cumprir a garantia do cliente, a HP exige que um técnico autorizado substitua a peça. Essas peças estão identificadas com a marca “No” (Não), no catálogo de peças ilustrado.

¹Mandatory : 必須 - 顧客自己修理が必須の部品。当該部品について、もしもお客様がHPに交換作業を依頼される場合には、その修理サービスに関する交通費および人件費がお客様に請求されます。

²Optional : 任意 - 顧客自己修理が任意である部品。この部品も顧客自己修理用です。当該部品について、もしもお客様がHPに交換作業を依頼される場合には、お買い上げの製品に適用される保証サービス内容の範囲内においては、費用を負担していただくことなく保証サービスを受けることができます。

³No : 除外 - HP製品の一部の部品は、顧客自己修理用ではありません。製品の保証を継続するためには、HPまたはHP正規保守代理店による交換作業が必須となります。部品カタログには、当該部品が顧客自己修理除外品である旨が記載されています。

¹Mandatory: 强制性的 — 要求客户必须自行维修的部件。如果您请求 HP 更换这些部件，则必须为该服务支付差旅费和人工费用。

²Optional: 可选的 — 客户可以选择是否自行维修的部件。这些部件也是为客户自行维修设计的。不过，如果您要求 HP 为您更换这些部件，则根据为您的产品指定的保修服务类型，HP 可能收取或不再收取任何附加费用。

³No: 否 — 某些 HP 部件的设计并未考虑客户自行维修。为了满足客户保修的需要，HP 要求授权服务提供商更换相关部件。这些部件在部件图解目录中标记为“否”。

¹Mandatory: 強制的 — 客戶自行維修所使用的零件是強制的。如果您要求 HP 更換這些零件，HP 將會向您收取此服務所需的外出費用與勞動成本。

²Optional: 選購的 — 客戶自行維修所使用的零件是選購的。這些零件也設計用於客戶自行維修之用。不過，如果您要求 HP 為您更換，則可能需要也可能不需要負擔額外的費用，端視針對此產品指定的保固服務類型而定。

³No: 否 — 某些 HP 零件沒有消費者可自行維修的設計。為符合客戶保固，HP 需要授權的服務供應商更換零件。這些零件在圖示的零件目錄中，被標示為「否」。

¹ Mandatory: 필수 — 고객 셀프 수리가 의무 사항인 필수 부품. 사용자가 HP에 이 부품의 교체를 요청할 경우 이 서비스에 대한 출장비 및 작업비가 청구됩니다.

² Optional: 옵션 — 고객 셀프 수리가 선택 사항인 부품. 이 부품들도 고객 셀프 수리가 가능하도록 설계되었습니다. 하지만 사용자가 HP에 이 부품의 교체를 요청할 경우 사용자가 구입한 제품에 해당하는 보증 서비스 유형에 따라 추가 비용 없이 교체가 가능할 수 있습니다.

³ No: No — 고객 셀프 수리가 불가능하도록 설계된 HP 부품. 이 부품들은 고객 셀프 수리가 불가능하도록 설계되었습니다. HP는 고객 보증을 만족시키기 위해 공인 서비스 제공업체를 통해 부품을 교체하도록 하고 있습니다.

System components

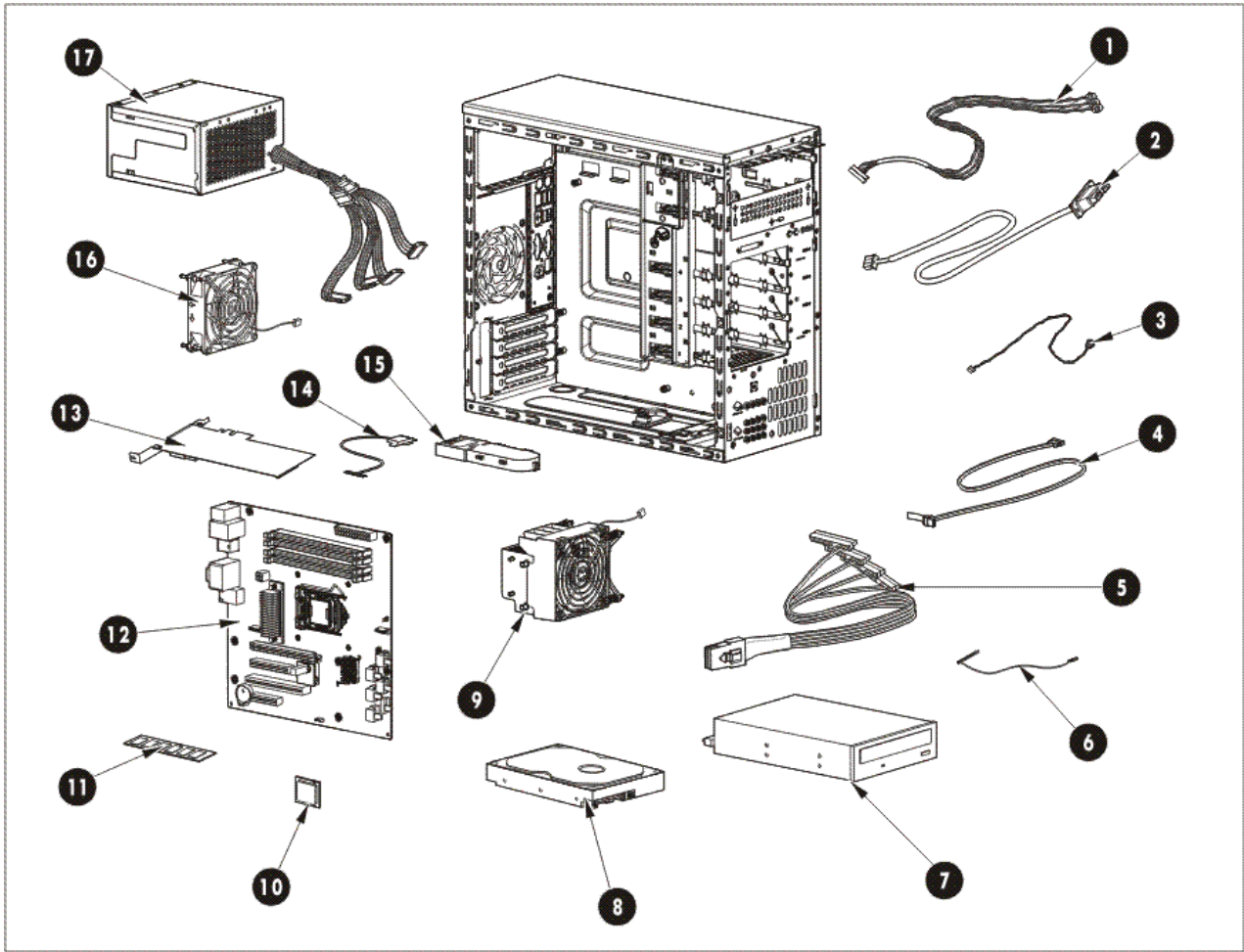

Item	Description	Spare part number	Customer self repair
System drive cables			Mandatory ¹
1	Power button / front panel LED cable	576929-001	
2	Front USB port cable	576928-001	
3	External ambient thermal sensor cable	592430-001	
4	SATA HDD / ODD cable	452334-001	
5	SAS HDD cable	576925-001	
6	SAS LED cable	576926-001	
Mass storage devices			Mandatory ¹
7	Optical disc drive (5.25 in)		
	a) SATA DVD-ROM drive	447464-001	
	b) SATA DVD-RW drive	447466-001	
8	160-GB non-hot-plug SATA hard drive	483096-001	
9	Heat sink	576927-001	Mandatory ¹
10	Processor (include alcohol pad and thermal compound)		Mandatory ¹
	a) Intel Xeon X3460	590323-001	
	b) Intel Xeon X3450	590324-001	
	c) Intel Xeon X3440	590325-001	
	d) Intel Xeon X3430	590326-001	
	e) Intel Celeron G1101	600639-001	
	f) Intel Pentium G6950	600128-001	
	g) Intel Core i3-530	600133-001	
	h) Intel Core i3-540	600134-001	
11	Memory module (ECC RoHS)		Mandatory ¹
	a) 1 GB PC3-10600E UDIMM	501539-001	
	b) 2 GB PC3-10600E UDIMM	501540-001	
	c) 4 GB PC3-1600E UDIMM	501541-001	
12	System board	576924-001	Mandatory ¹
13	SAS controller board	462594-001	Mandatory ¹
14	BBWC (Battery Back Write Cache) cable	488137-001	Mandatory ¹
15	SAS cache battery option kit	398648-001	Mandatory ¹
16	System fan	576930-001	Mandatory ¹
17	300W power supply unit with cable assembly	576931-001	Mandatory ¹

Item	Description	Spare part number	Customer self repair
18	FBWC capacitor pack	587324-001	Mandatory ¹
19	FBWC cache module, 512-MB	578882-001	Mandatory ¹
20	FBWC cache module, 1-GB	505908-001	Mandatory ¹

¹Mandatory—Parts for which customer self repair is mandatory. If, however, you require that HP replace them for you, there may or may not be additional charges, depending on the type of warranty service designated for your product.

²Optional—Parts for which customer self repair is optional. These parts are also designed for customer self repair. If, however, you require that HP replace them for you, there may or may not be additional charges, depending on the type of warranty service designated for your product.

³No—Some HP parts are not designed for customer self repair. In order to satisfy the customer warranty, HP requires that an authorized service provider replace the part. These parts are identified as "No" in the Illustrated Parts Catalog.

¹Mandatory: Obligatoire—Pièces pour lesquelles la réparation par le client est obligatoire. Si vous demandez à HP de remplacer ces pièces, les coûts de déplacement et main d'œuvre du service vous seront facturés.

²Optional: Facultatif—Pièces pour lesquelles la réparation par le client est facultative. Ces pièces sont également conçues pour permettre au client d'effectuer lui-même la réparation. Toutefois, si vous demandez à HP de remplacer ces pièces, l'intervention peut ou non vous être facturée, selon le type de garantie applicable à votre produit.

³No: Non—Certaines pièces HP ne sont pas conçues pour permettre au client d'effectuer lui-même la réparation. Pour que la garantie puisse s'appliquer, HP exige que le remplacement de la pièce soit effectué par un Mainteneur Agréé. Ces pièces sont identifiées par la mention "Non" dans le Catalogue illustré.

¹Mandatory: Obbligatorie—Parti che devono essere necessariamente riparate dal cliente. Se il cliente ne affida la riparazione ad HP, deve sostenere le spese di spedizione e di manodopera per il servizio.

²Optional: Opzionali—Parti la cui riparazione da parte del cliente è facoltativa. Si tratta comunque di componenti progettati per questo scopo. Se tuttavia il cliente ne richiede la sostituzione ad HP, potrebbe dover sostenere spese addizionali a seconda del tipo di garanzia previsto per il prodotto.

³No: Non CSR—Alcuni componenti HP non sono progettati per la riparazione da parte del cliente. Per rispettare la garanzia, HP richiede che queste parti siano sostituite da un centro di assistenza autorizzato. Tali parti sono identificate da un "No" nel Catalogo illustrato dei componenti.

¹Mandatory: Zwingend—Teile, die im Rahmen des Customer Self Repair Programms ersetzt werden müssen. Wenn Sie diese Teile von HP ersetzen lassen, werden Ihnen die Versand- und Arbeitskosten für diesen Service berechnet.

²Optional: Optional—Teile, für die das Customer Self Repair-Verfahren optional ist. Diese Teile sind auch für Customer Self Repair ausgelegt. Wenn Sie jedoch den Austausch dieser Teile von HP vornehmen lassen möchten, können bei diesem Service je nach den für Ihr Produkt vorgesehenen Garantiebedingungen zusätzliche Kosten anfallen.

³No: Kein—Einige Teile sind nicht für Customer Self Repair ausgelegt. Um den Garantieanspruch des Kunden zu erfüllen, muss das Teil von einem HP Servicepartner ersetzt werden. Im illustrierten Teilekatalog sind diese Teile mit „No“ bzw. „Nein“ gekennzeichnet.

¹Mandatory: Obligatorio—componentes para los que la reparación por parte del usuario es obligatoria. Si solicita a HP que realice la sustitución de estos componentes, tendrá que hacerse cargo de los gastos de desplazamiento y de mano de obra de dicho servicio.

²Optional: Opcional— componentes para los que la reparación por parte del usuario es opcional. Estos componentes también están diseñados para que puedan ser reparados por el usuario. Sin embargo, si precisa que HP realice su sustitución, puede o no conllevar costes adicionales, dependiendo del tipo de servicio de garantía correspondiente al producto.

³No: No—Algunos componentes no están diseñados para que puedan ser reparados por el usuario. Para que el usuario haga valer su garantía, HP pone como condición que un proveedor de servicios autorizado realice la sustitución de estos componentes. Dichos componentes se identifican con la palabra “No” en el catálogo ilustrado de componentes.

¹Mandatory: Verplicht—Onderdelen waarvoor Customer Self Repair verplicht is. Als u HP verzoekt deze onderdelen te vervangen, komen de reiskosten en het arbeidsloon voor uw rekening.

²Optional: Optioneel—Onderdelen waarvoor reparatie door de klant optioneel is. Ook deze onderdelen zijn ontworpen voor reparatie door de klant. Als u echter HP verzoekt deze onderdelen voor u te vervangen, kunnen daarvoor extra kosten in rekening worden gebracht, afhankelijk van het type garanteservice voor het product.

³No: Nee—Sommige HP onderdelen zijn niet ontwikkeld voor reparatie door de klant. In verband met de garantievoorwaarden moet het onderdeel door een geautoriseerde Service Partner worden vervangen. Deze onderdelen worden in de geïllustreerde onderdelencatalogus aangemerkt met “Nee”.

¹Mandatory: Obrigatória—Peças cujo reparo feito pelo cliente é obrigatório. Se desejar que a HP substitua essas peças, serão cobradas as despesas de transporte e mão-de-obra do serviço.

²Optional: Opcional—Peças cujo reparo feito pelo cliente é opcional. Essas peças também são projetadas para o reparo feito pelo cliente. No entanto, se desejar que a HP as substitua, pode haver ou não a cobrança de taxa adicional, dependendo do tipo de serviço de garantia destinado ao produto.

³No: Nenhuma—Algumas peças da HP não são projetadas para o reparo feito pelo cliente. A fim de cumprir a garantia do cliente, a HP exige que um técnico autorizado substitua a peça. Essas peças estão identificadas com a marca “No” (Não), no catálogo de peças ilustrado.

¹Mandatory : 必須 - 顧客自己修理が必須の部品。当該部品について、もしもお客様がHPに交換作業を依頼される場合には、その修理サービスに関する交通費および人件費がお客様に請求されます。

²Optional : 任意 - 顧客自己修理が任意である部品。この部品も顧客自己修理用です。当該部品について、もしもお客様がHPに交換作業を依頼される場合には、お買い上げの製品に適用される保証サービス内容の範囲内においては、費用を負担していただくことなく保証サービスを受けることができます。

³No : 除外 - HP製品の一部の部品は、顧客自己修理用ではありません。製品の保証を継続するためには、HPまたはHP正規保守代理店による交換作業が必須となります。部品カタログには、当該部品が顧客自己修理除外品である旨が記載されています。

¹Mandatory: 强制性的 — 要求客户必须自行维修的部件。如果您请求 HP 更换这些部件，则必须为该服务支付差旅费和人工费用。

²Optional: 可选的 — 客户可以选择是否自行维修的部件。这些部件也是为客户自行维修设计的。不过，如果您要求 HP 为您更换这些部件，则根据为您的产品指定的保修服务类型，HP 可能收取或不再收取任何附加费用。

³No: 否 — 某些 HP 部件的设计并未考虑客户自行维修。为了满足客户保修的需要，HP 要求授权服务提供商更换相关部件。这些部件在部件图解目录中标记为“否”。

¹Mandatory: 強制的 — 客戶自行維修所使用的零件是強制的。如果您要求 HP 更換這些零件，HP 將會向您收取此服務所需的外出費用與勞動成本。

²Optional: 選購的 — 客戶自行維修所使用的零件是選購的。這些零件也設計用於客戶自行維修之用。不過，如果您要求 HP 為您更換，則可能需要也可能不需要負擔額外的費用，端視針對此產品指定的保固服務類型而定。

³No: 否 — 某些 HP 零件沒有消費者可自行維修的設計。為符合客戶保固，HP 需要授權的服務供應商更換零件。這些零件在圖示的零件目錄中，被標示為「否」。

¹ Mandatory: 필수 — 고객 셀프 수리가 의무 사항인 필수 부품. 사용자가 HP에 이 부품의 교체를 요청할 경우 이 서비스에 대한 출장비 및 작업비가 청구됩니다.

² Optional: 옵션 — 고객 셀프 수리가 선택 사항인 부품. 이 부품들도 고객 셀프 수리가 가능하도록 설계되었습니다. 하지만 사용자가 HP에 이 부품의 교체를 요청할 경우 사용자가 구입한 제품에 해당하는 보증 서비스 유형에 따라 추가 비용 없이 교체가 가능할 수 있습니다.

³ No: No — 고객 셀프 수리가 불가능하도록 설계된 HP 부품. 이 부품들은 고객 셀프 수리가 불가능하도록 설계되었습니다. HP는 고객 보증을 만족시키기 위해 공인 서비스 제공업체를 통해 부품을 교체하도록 하고 있습니다.

HP contact information

For the name of the nearest HP authorized reseller:

- In the United States, call 1-800-345-1518.
- In Canada, call 1-800-263-5868.
- In other locations, refer to the HP website at www.hp.com.

For HP technical support:

- In North America:
 - Call 1-800-HP-INVENT (1-800-474-6836). This service is available 24 hours a day, 7 days a week. For continuous quality improvement, calls may be recorded or monitored.
 - If you have purchased a Care Pack (service upgrade), call 1-800-633-3600. For more information about Care Packs, refer to the HP website at www.hp.com.
- Outside North America, call the nearest HP Technical Support Phone Center. For telephone numbers of worldwide Technical Support Centers, refer to the HP website at www.hp.com.

Before you contact HP

Be sure to have the following information available before you call HP:

- Technical support registration number (if applicable)
- Product serial number (printed on the serial pull tab located on the front panel)
- Product model name and number
- Applicable error messages
- Add-on boards or hardware
- Third-party hardware or software
- Operating system type and revision level

Removal and replacement procedures

Required tools

In performing any hardware configuration procedure you may need the following tools:

- Phillips screwdriver (for installation in the second removable drive bay)
- T-15 Torx screwdriver (for processor replacement)
- Flat-blade screwdriver (for system battery replacement)

The following references and software tools may also be used:

- *HP ProLiant ML110 G6 Server Easy Set-up CD*
- IPMI Event Log
- Diagnostics software

Server warnings and cautions

Before installing a server, be sure that you understand the following warnings and cautions.

 **WARNING:** To reduce the risk of personal injury from hot surfaces, allow the drives and the internal system components to cool before touching them.

 **CAUTION:** The server must always be operated with the system covers on. Proper cooling is not achieved when the system covers are removed.

 **CAUTION:** Whenever installing hardware or performing maintenance procedures requiring access to internal components, it is recommended that users first back up all server data to avoid loss.

 **IMPORTANT:** Before removing any serviceable parts, determine whether the part is hot-plug or non-hot-plug. If the device is non-hot-plug, you must power down the server. Non-hot-plug devices in the server include the processor, all boards, memory modules, fans, expansion boards, and all system drives.

 **IMPORTANT:** Review the specifications of a new component before installing it to make sure it is compatible with the server. When you integrate new components into the system, record its model and serial number, and any other pertinent information for future reference. After completing any removal or replacement procedure, run the diagnostics program to verify that all components operate properly.

Symbols on equipment

The following symbols may be placed on equipment to indicate the presence of potentially hazardous conditions.



This symbol indicates the presence of hazardous energy circuits or electric shock hazards. Refer all servicing to qualified personnel.

WARNING: To reduce the risk of injury from electric shock hazards, do not open this enclosure. Refer all maintenance, upgrades, and servicing to qualified personnel.



This symbol indicates the presence of electric shock hazards. The area contains no user or field serviceable parts. Do not open for any reason.

WARNING: To reduce the risk of injury from electric shock hazards, do not open this enclosure.



This symbol on an RJ-45 receptacle indicates a network interface connection.

WARNING: To reduce the risk of electric shock, fire, or damage to the equipment, do not plug telephone or telecommunications connectors into this receptacle.



This symbol indicates the presence of a hot surface or a hot component. If this surface is touched, the potential for injury exists.

WARNING: To reduce the risk of injury from a hot component, allow the surface to cool before touching.



weight1_kg
weight1_lb

This symbol indicates that the component exceeds the recommended weight for one individual to handle safely.

WARNING: To reduce the risk of personal injury or damage to the equipment, observe local occupational health and safety requirements and guidelines for manual material handling.



These symbols, on power supplies or systems, indicate that the equipment is supplied by multiple sources of power.

WARNING: To reduce the risk of injury from electric shock, remove all power cords to completely disconnect power from the system.

Electrostatic discharge information

An electrostatic discharge (ESD) can damage static-sensitive devices or microcircuitry. Proper packaging and grounding techniques are necessary precautions to prevent damage. To prevent electrostatic damage, observe the following precautions:

- Transport products in static-safe containers such as conductive tubes, bags, or boxes.
- Keep electrostatic-sensitive parts in their containers until they arrive at static-free stations.
- Cover workstations with approved static-dissipating material. Use a wrist strap connected to the work surface, and properly grounded (earthed) tools and equipment.
- Keep work area free of nonconductive materials, such as ordinary plastic assembly aids and foam packing.
- Make sure that you are always properly grounded (earthed) when touching a static-sensitive component or assembly.
- Avoid touching pins, leads, or circuitry.
- Always place drives with the Printed Circuit Board (PCB) assembly-side down.
- Use conductive field service tools.

Pre-installation procedure

Perform the steps below before you open the server or before you remove or replace any component.

1. Perform data backup.
2. Turn off the server and all the peripherals connected to it.
3. Unplug all cables from the power outlets to avoid exposure to high energy levels that may cause burns when parts are short circuited by metal objects such as tools or jewelry.
4. If necessary, label each cable to expedite reassembly.
5. Disconnect all telecommunication cables to avoid exposure to shock hazard from ringing voltages.
6. Open the server according to the instructions described in the “[System covers](#)” section on [page 32](#).
7. Follow the ESD precautions listed previously in this chapter when handling any hardware component.



IMPORTANT: To streamline the configuration process, read through the entire [installation/removal procedure](#) first and make sure you understand it before you begin.

Post-installation procedure

Perform the steps below after installing or removing a server component.

1. Be sure all components are installed according to the described step-by-step instructions.
2. Check to make sure you have not left loose tools or parts inside the server.
3. Reinstall any expansion board, peripheral, and system cables that have previously been removed.

⚠ CAUTION: Do not operate the server for more than 10 minutes with the access panel and disk drives removed. Otherwise, improper cooling airflow may damage the system components.

4. Reinstall the system covers.
5. Connect all external cables and the AC power cord to the system.
6. Press the power button  on the front panel to turn on the server.

Powering down the server

The server does not completely power down when the power button  is pressed. The button toggles between On and Standby. The standby position removes power from most electronics and the drives, but some internal circuitry remains active. To completely remove all power from the system, disconnect all power cords from the server.

⚠ WARNING: Hazardous voltages are present inside the server. Always disconnect AC power from the server and other associated assemblies while working inside the unit. Serious injury may result if this warning is not observed.

⚠ WARNING: To reduce the risk of electric shock or damage to the equipment:

- Do not disable the power cord grounding plug. The grounding plug is an important safety feature.
- Plug the power cord into a grounded (earthed) electrical outlet that is easily accessible at all times.
- Unplug the power cord from the power supply to disconnect power to the equipment.
- Do not route the power cord where it can be walked on or pinched by items placed against it. Pay particular attention to the plug, electrical outlet, and the point where the cord extends from the server.

⚠ CAUTION: Protect the server from power fluctuations and temporary interruptions with a regulating uninterruptible power supply (UPS). This device protects the hardware from damage caused by power surges and voltage spikes, and keeps the system in operation during a power failure.

1. Shut down the server as directed by the operating system documentation.
2. Press the power button  to toggle to Standby.

This places the server in standby mode changing the power LED indicator to amber. In this mode, the main power supply output is disabled. Standby does not completely disable or remove power from the system.

3. Disconnect the AC power cord from the AC outlet and then from the server.
4. Check that the power LED indicator is turned off and that the fan noise has stopped.
5. Disconnect all external peripheral devices from the server.

Cable management

Always follow good cable management practices when working inside the computer.

- Keep cables away from major heat sources like the heat sink.
- Do not jam cables on top of expansion cards or memory modules. Printed circuit cards are not designed to withstand excessive pressure.
- Keep cables clear of sliding or moveable parts to prevent cutting or crimping.
- When folding a flat ribbon cable, never fold to a sharp crease. Sharp creases may damage the wires.
- Some flat ribbon cables come prefolded. Never change the folds on these cables.
- Do not sharply bend any cable. A sharp bend can break the internal wires.
- Never bend a SATA data cable tighter than a 30 mm (1.18 in) radius.
- Never crease a SATA data cable.
- Do not rely on components like the drive cage, power supply, or system cover to push cables down into the chassis.

To disconnect a power supply cable from the system board:

⚠ CAUTION: Always pull the connector. NEVER pull on the cable. Pulling on the cable can damage the cable and result in a failed power supply.

Grasp the cable end and pull it away from its connector.

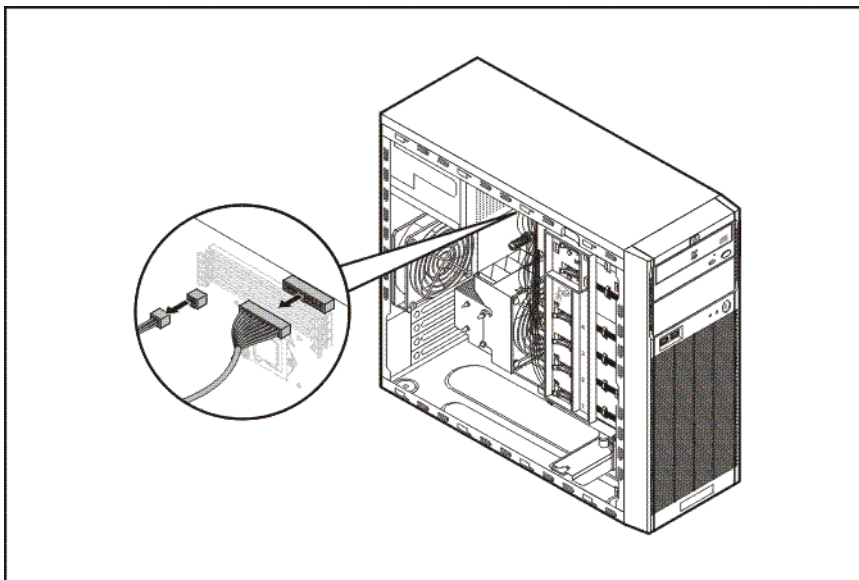

System covers

The access panel and the front bezel are both detachable. You must remove these system covers before you can remove or replace a server component.

Access panel

The access panel must be removed to access the internal components and the non-hot-plug mass storage devices.

To remove the access panel:

1. Perform steps 1 through 4 of the pre-installation procedure.
2. Loosen the captive thumbscrew located on the rear edge of the access panel.
3. Slide the panel back about 2.5 cm (1.0 in) to release it from the chassis notch.
4. Detach the panel from the chassis.

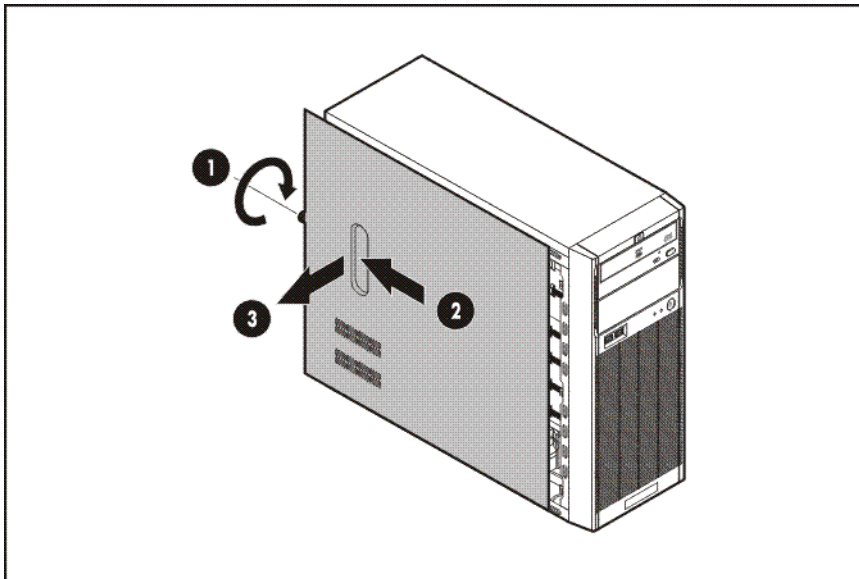

5. Place the access panel in a safe place for reinstallation later.

Front bezel

The front bezel must be removed to access the hard drives and the removable media devices.

To remove the front bezel:

1. Remove the access panel.
2. Remove the front bezel.
 - a. Press the three release tabs (marked by white arrows) located on the inner left edge of the bezel (1).
 - b. Rotate the bezel out slightly, and then pull it away from the front panel (2).

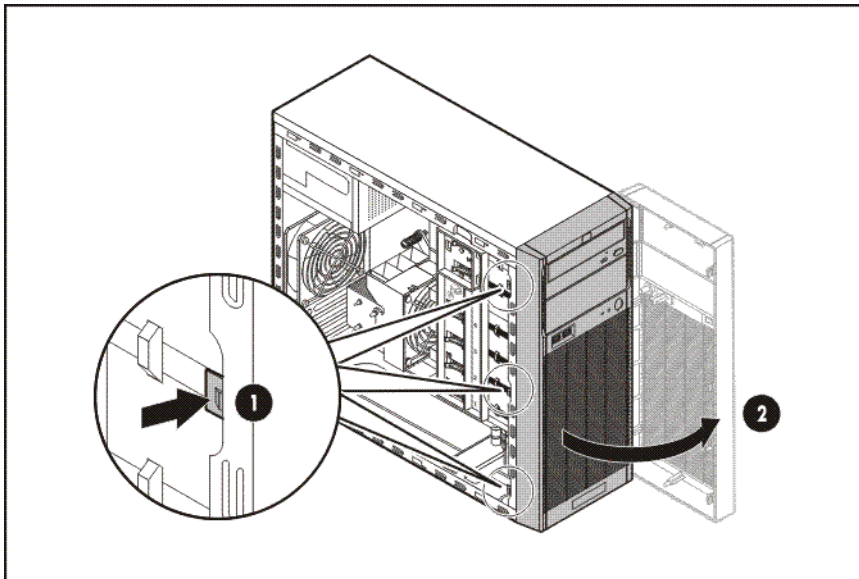

3. Place the front bezel in a safe place for reinstallation later.

Drive bay configuration

The server supports a maximum of six internal drives. The two upper drive bays are primarily for removable media drives, while the four lower drive bays are only for hard drives.

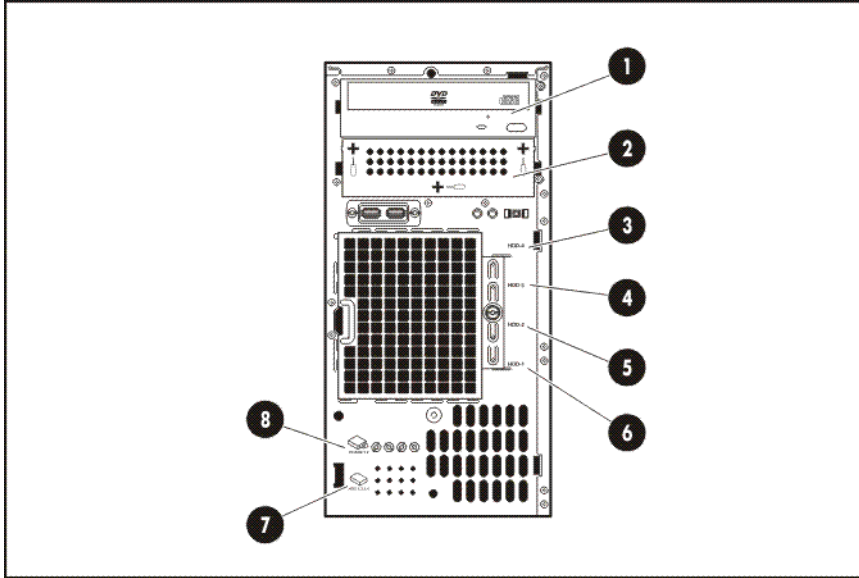

Item	Description
1	1 st removable media drive
2	2 nd removable media drive
3	4 th SAS/SATA hard drive
4	3 rd SAS/SATA hard drive
5	2 nd SAS/SATA hard drive
6	1 st SAS/SATA hard drive
7	HDD spare screws
8	Removable media drive spare screws

NOTE: The server does not support SAS and SATA HDD models at the same time.

System drive cable management

The figures in this section illustrate the system drives' data and power cable connections. Observe the proper cable management guidelines described on [page 31](#) when routing the cables.

Data cable management

SATA hard drive cables

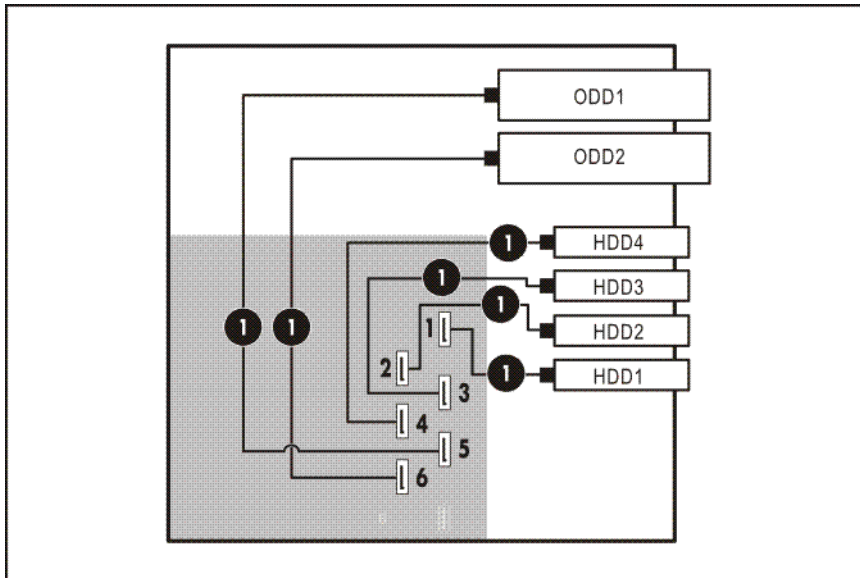

SAS hard drive cables

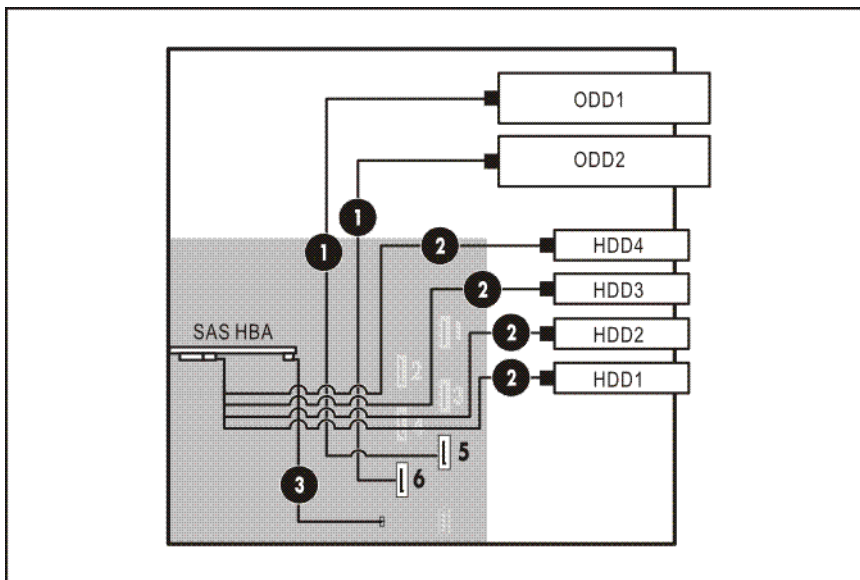

Item	Description
1	SATA cables
2	SAS HDD cable
3	SAS LED cable

Power cable management

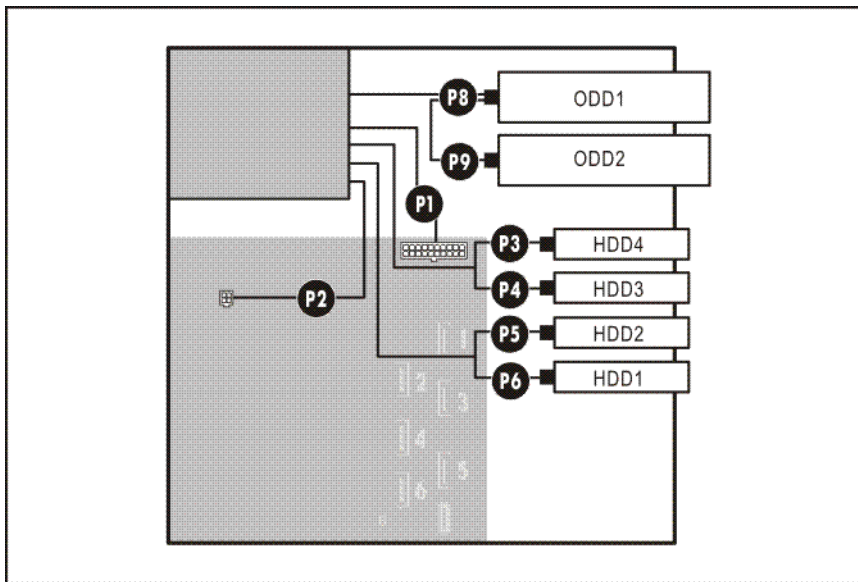

PSU cable label	Connects to
P8	1 st removable media drive
P9	2 nd removable media drive
P3	4 th hard drive
P4	3 rd hard drive
P5	2 nd hard drive
P6	1 st hard drive
P1	24-pin power connector (ATXPWRCN1)
P2	4-pin power connector (ATXPWRCN2)

Removable media drives

The two upper bays are half height bays that can accommodate a variety of removable media drives including:

- CD, DVD, CD-RW/DVD combo, DVD-RW drives
- DAT 24i, 40i, 72i, Disk to Disk Backup Autoloaders (Internal/External) DAT 40x6, 72x6 drives

To install a removable media drive:

1. Perform the pre-installation procedure.
2. Do one of the following:
 - If you intend to replace an old media drive, proceed to step 3.
 - If you intend to install a new media drive in the empty second removable media drive bay, proceed to step 4.
3. Remove the media drive you intend to replace.
 - a. Disconnect the power and data cables from the back of the installed drive (1).
 - b. Pull and hold the release tab on the drive latch for the device you want to remove (2).
 - c. Slide the device out of the drive bay (3).

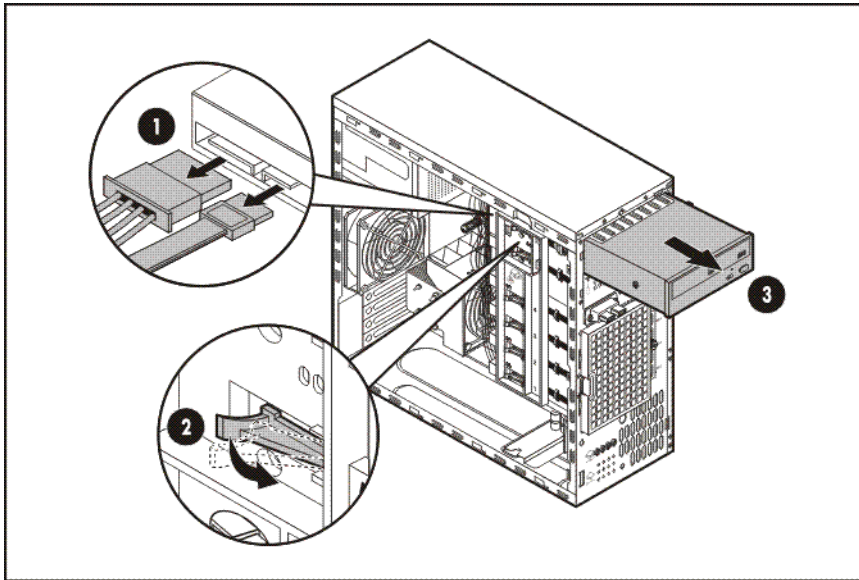

- d. Remove four screws from the sides of the drive.
Reuse these screws when you install the new removable media drive.

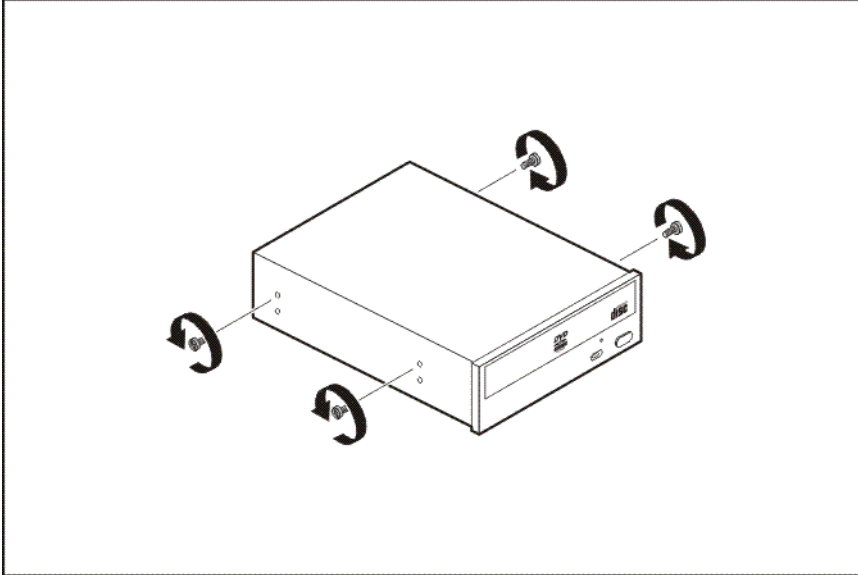

- e. Place the old media drive on a static-dissipating work surface or inside an anti-static bag.
- f. Proceed to step 5.

⚠ CAUTION: Do not discard the EMI shield. If the drive is removed in the future, you must reinstall the shield to maintain proper cooling.

4. Remove the EMI shield from the second removable media drive bay.
 - a. Insert a Phillips screwdriver to the marked openings (+) on the shield to dislodge it from the chassis (1).
 - b. Remove the EMI shield from the chassis (2)

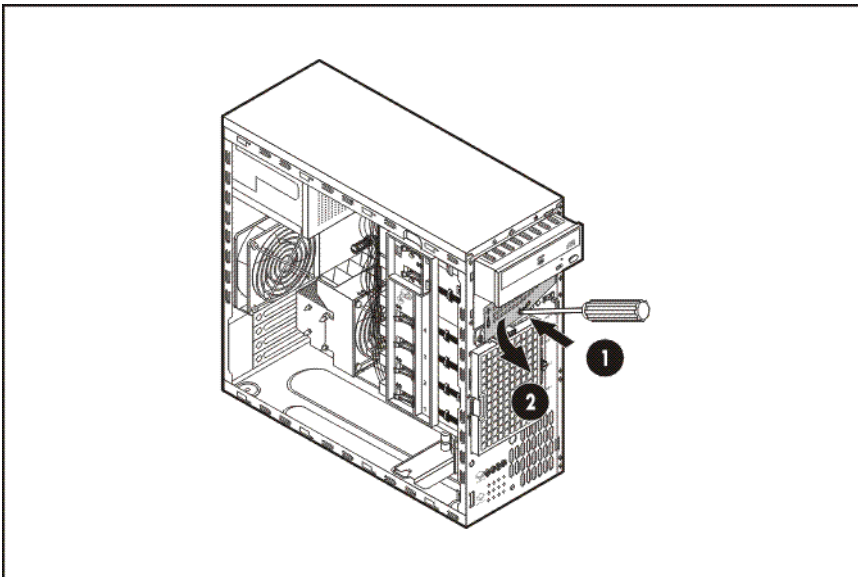

5. Remove the new media drive from its protective packaging.
6. Do one of the following:
 - If you intend to replace an old media drive, insert the four screws you removed in step 3-d into the top screw holes on the sides of the new media drive.
 - If you intend to install an additional media drive, remove four spare removable media drive screws from the front chassis, and then insert them into the top screw holes on the sides of the new media drive.
7. Install the new media drive.
 - a. Slide the new media drive into the selected bay until it clicks into place (1).
 - b. Connect the data and power cables to the back of the media drive (2).

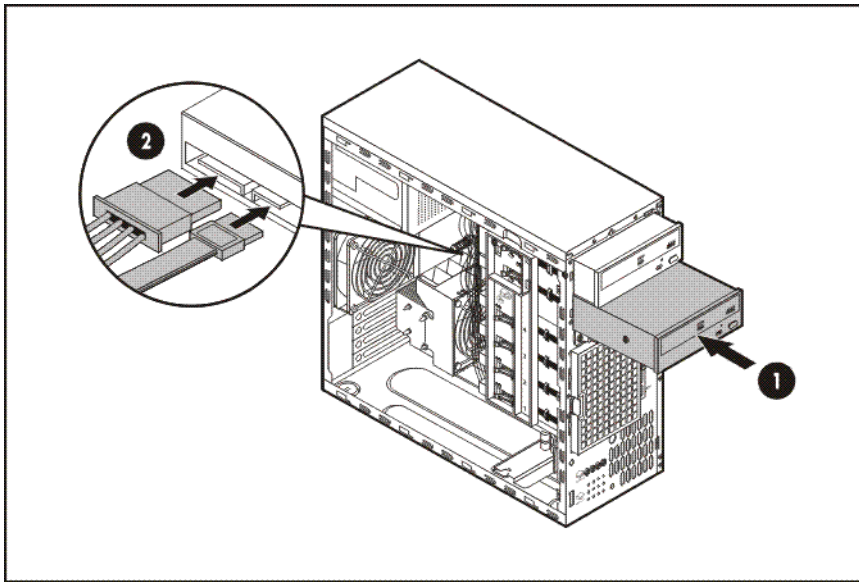

8. Perform the post-installation procedure.

Hard drives

The four lower drive bays can accommodate 3.5-inch non-hot-plug SAS or SATA hard drives. The following drive capacities are supported.

- Non-hot-plug SAS HDD – 146-, 300-, 400-, and 450-GB
- Non-hot-plug SATA HDD – 160-, 250-, 500-, and 750-GB; 1-TB



IMPORTANT: SAS hard drives require that you also install a SAS controller board. This board should be installed in the full-height/full-length PCIe Gen1 x8 expansion slot. For more information about installing the SAS controller board, see [page 58](#).

To install a hard drive:

1. Perform the pre-installation procedure.
2. Remove the HDD EMI shield.
 - a. Loosen the HDD EMI shield thumbscrew (1).
 - b. Slide the shield slightly to the right to release the shield tabs (2), and then pull it away from the chassis (3).

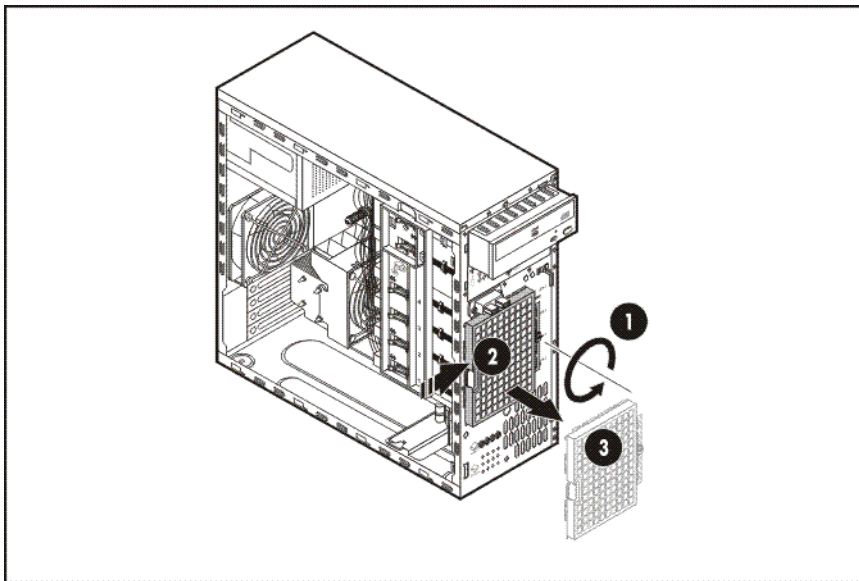

3. Do one of the following:
 - If you intend to replace an old hard drive, proceed to step 4.
 - If you intend to install an additional hard drive, proceed to step 5.

4. Remove the hard drive you intend to replace.
 - a. For a SATA drive, disconnect the power and data cables from the back of the installed drive (1).
For a SAS drive, disconnect the SAS HDD cable from the back of the installed drive.
 - b. Pull and hold the corresponding drive release tab (2).
 - c. Slide the hard drive from the drive bay (3).

SATA drive

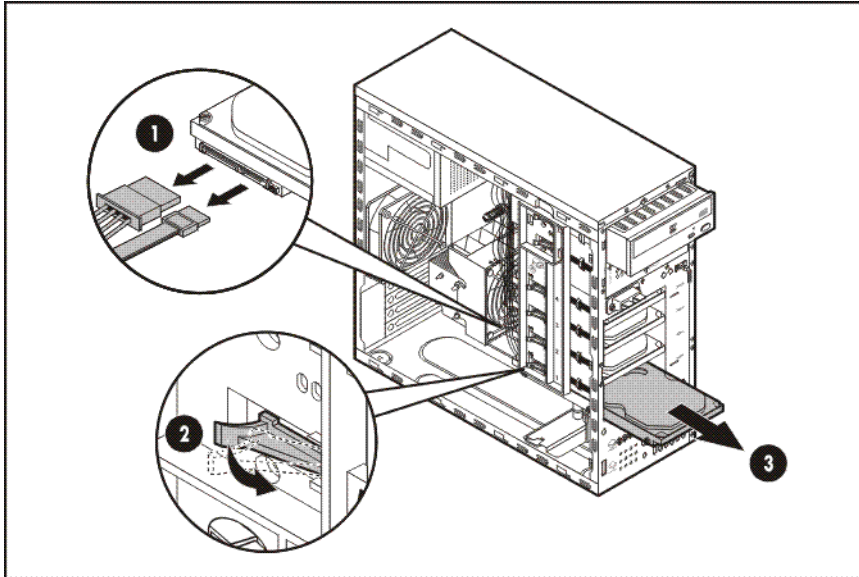

SAS drive

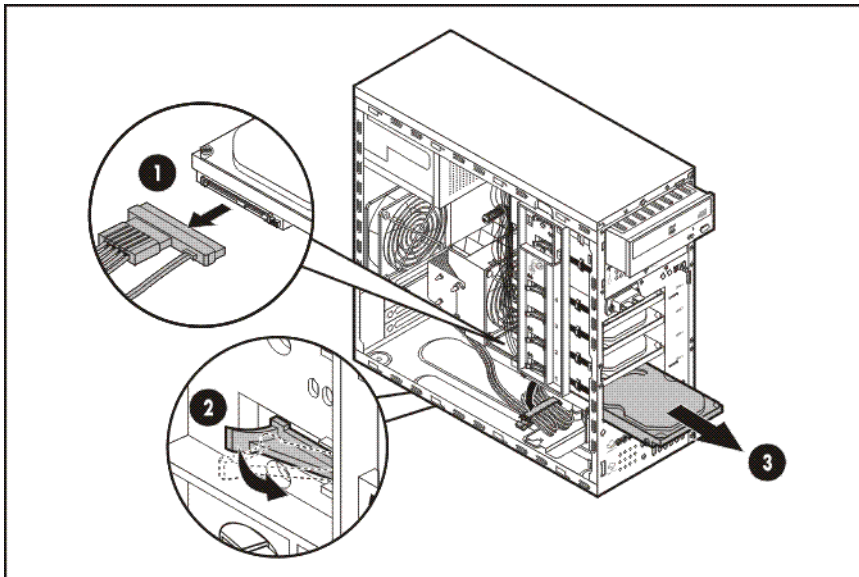

- d. Remove four screws from the sides of the drive.
Reuse these screws when you install the new hard drive.

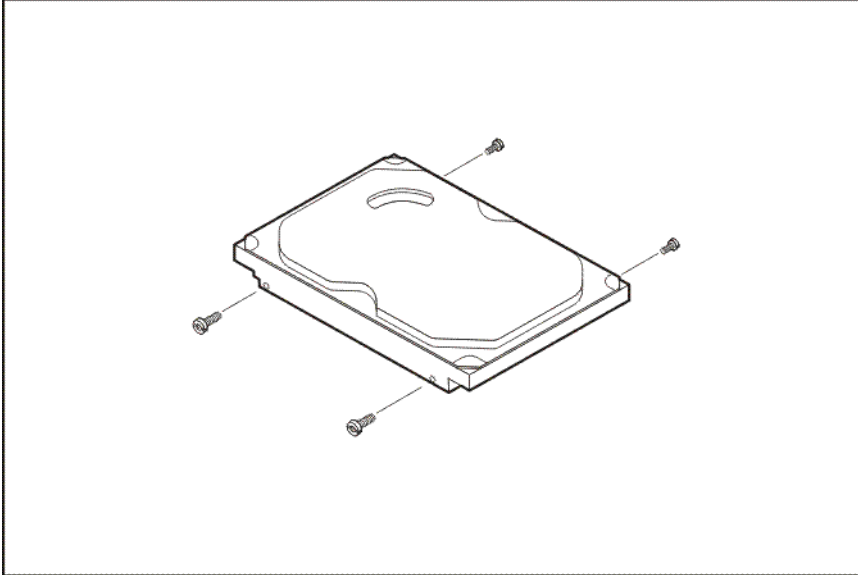

- e. Place the old hard drive on a static-dissipating work surface or inside an anti-static bag.
5. Remove the new hard drive from its protective packaging.
6. Do one of the following:
- If you intend to replace an old hard drive, insert the four screws you removed in step 4-d into the new drive.
 - If you intend to install an additional hard drive, remove four spare HDD screws from the front chassis, and then insert them into the new drive.
7. Install the new SATA hard drive.
- a. Slide the new hard drive into the selected bay until it clicks into place (1).
- b. Connect the power and data cables to the back of the hard drive (2).

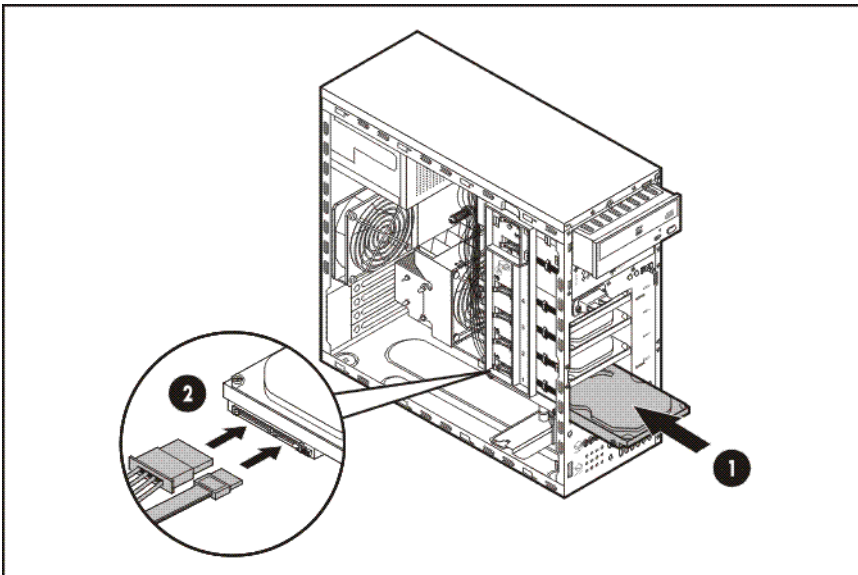

8. Install the new SAS hard drive.
 - a. Slide the new hard drive into the selected bay until it clicks into place (1).
 - b. Connect the SAS HDD data cable to the back of the hard drive (2).
 - c. Connect the drive power cable to the back of the SAS HDD cable (3).

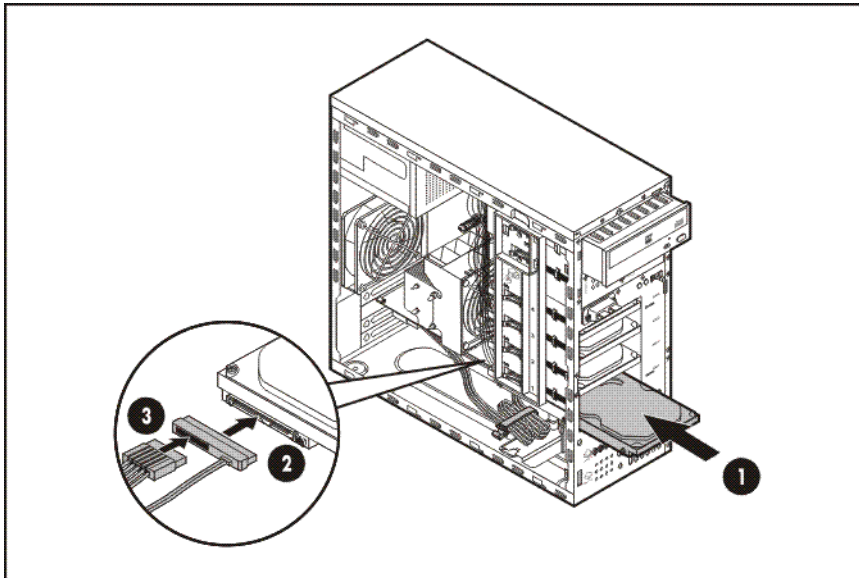

9. Perform the post-installation procedure.

System board configuration

Refer to the following sections for instructions about how to remove or replace the processor, the memory modules, the expansion cards, and the system battery. The procedure for installing the Lights-Out 100c remote management card option is also provided.

Processor

The Intel LGA 1156 processor socket supports the following Intel Xeon 3400 series processors:

- Intel Xeon X3460
- Intel Xeon X3450
- Intel Xeon X3440
- Intel Xeon X3430
- Intel Celeron G1101
- Intel Pentium G6950
- Intel Core i3-530
- Intel Core i3-540

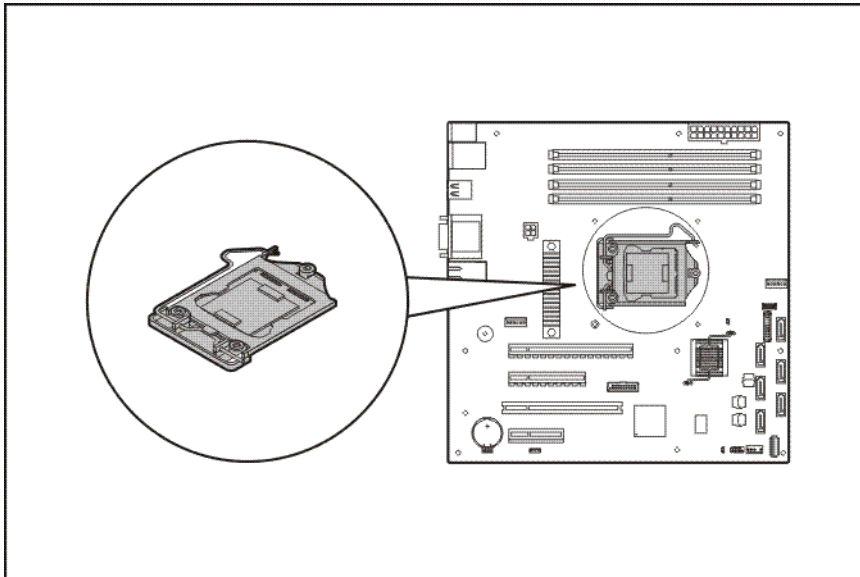

Processor installation guidelines

When configuring the processor, observe the following important guidelines:

- Handle the processor and heat sink with care. Damage to either may prevent the system from functioning properly.
- Be sure that the server has the most recent ROM version. Failure to flash the ROM before installing processors can cause system failure.

Processor installation

⚠ WARNING: To reduce the risk of personal injury from hot surfaces, allow the heat sink and the processor to cool before touching them.

⚠ CAUTION: To prevent the heat sink from tilting to one side during installation/removal procedures, observe a diagonally opposite pattern (an “X” pattern) when loosening and tightening the four spring loaded screws.

The procedure for replacing the current processor consists of five major steps which are as follows:

1. Remove the heat sink.
2. Remove the current processor.
3. Install the new processor.
4. Apply the thermal compound.
5. Install the CPU heatsink.

To remove the heat sink:

1. Prior to removing the heat sink, power on the system for a few minutes to soften the thermal compound, so that the fan can easily be removed.
2. Perform the pre-installation procedure.
3. Lay the server on its side (components showing).
4. Remove the heat sink.
 - a. Disconnect the heat sink cable from its system board connector (1).
 - b. Use a T-15 Torx screwdriver to loosen the four spring-loaded screws of the heat sink (2).
 - c. Lift the heat sink away from the system board (3).

You may need to rotate the heat sink a few degrees clockwise and counterclockwise to break the thermal compound bond.

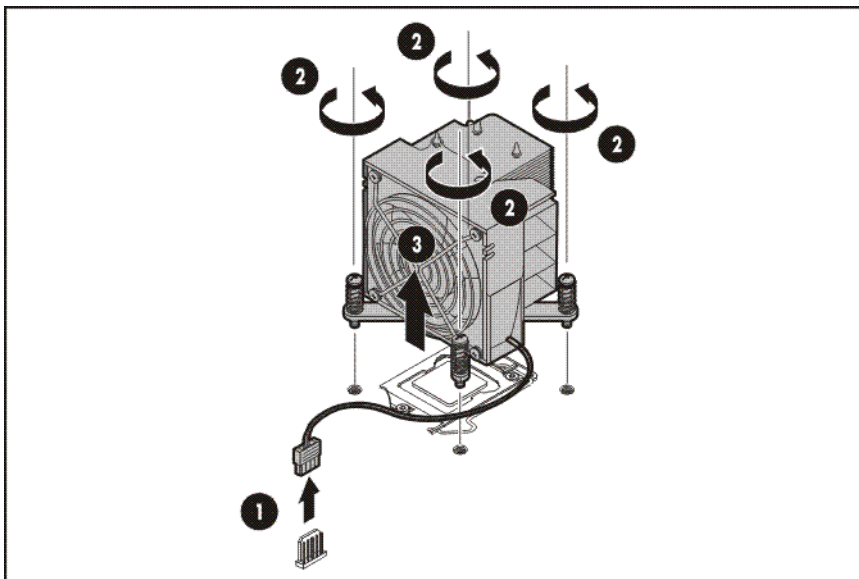

To remove the default processor:

1. Open the processor locking lever and the processor socket retaining bracket.

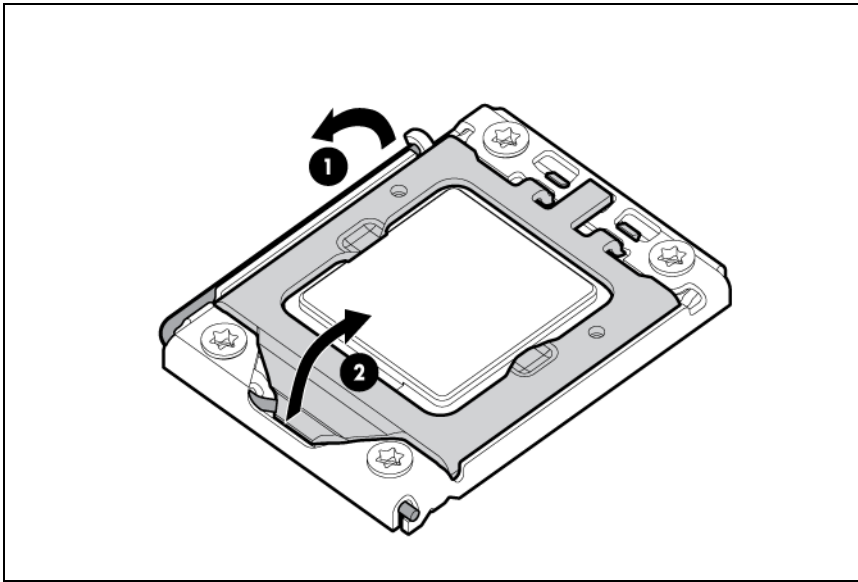

2. Using the processor removal tool, remove the processor from the system board:
 - a. Line up the processor tool, ensuring the locking lever graphic on the tool is correctly oriented.
 - b. Press in on the plastic tabs, and then place the tool on the processor.
 - c. Release the tabs, and then carefully lift the processor and tool straight up.

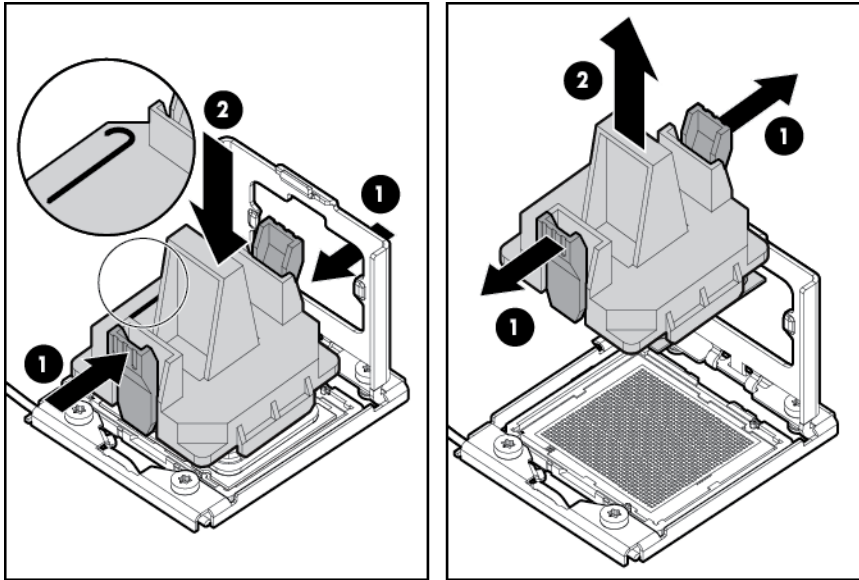

3. Carefully rotate the tool, and then push in and release the tabs to secure the processor in the tool.

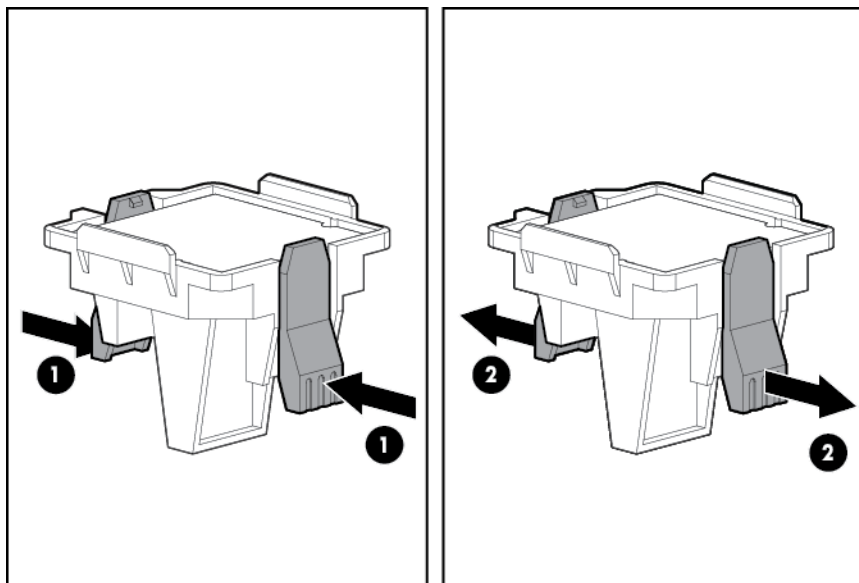

CAUTION: To avoid damage to the processor, do not touch the bottom of the processor, especially the contact area.

To install the new processor:

1. Carefully insert the processor into the processor installation tool. Handle the processor by the edges only, and do not touch the bottom of the processor, especially the contact area.

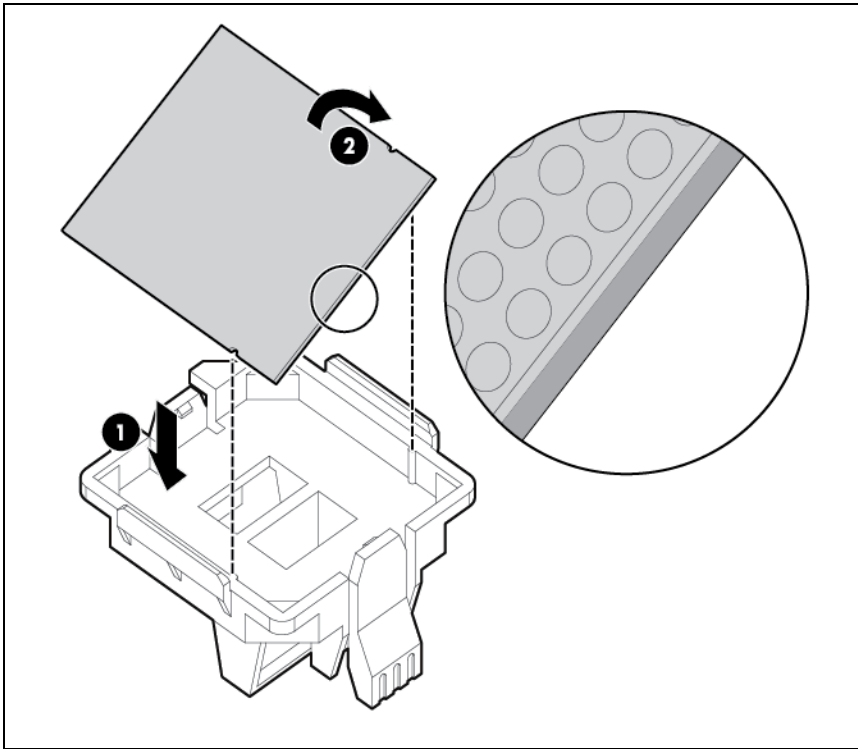

2. Be sure the tool is oriented correctly. Align the processor installation tool with the socket, and then install the processor. **THE PINS ON THE SYSTEM BOARD ARE VERY FRAGILE AND EASILY DAMAGED.**

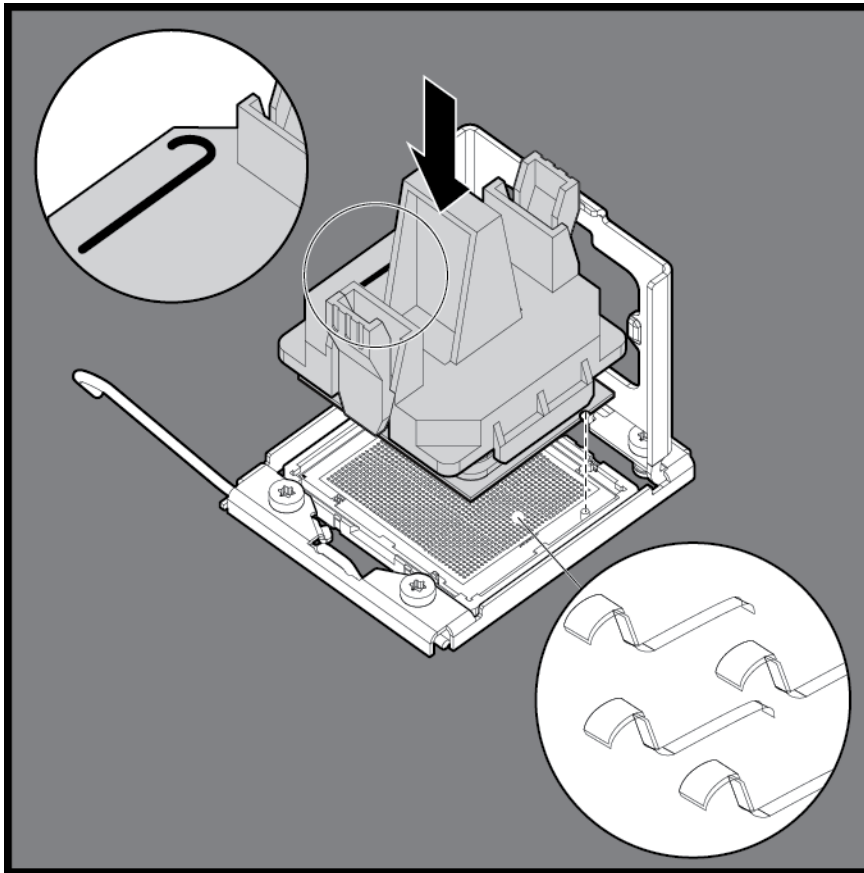

⚠ CAUTION: THE PINS ON THE SYSTEM BOARD ARE VERY FRAGILE AND EASILY DAMAGED. To avoid damage to the system board:

- Never install or remove a processor without using the processor installation tool.
- Do not touch the processor socket contacts.
- Do not tilt or slide the processor when lowering the processor into the socket.

3. Press and hold the tabs on the processor installation tool to separate it from the processor, and then remove the tool.

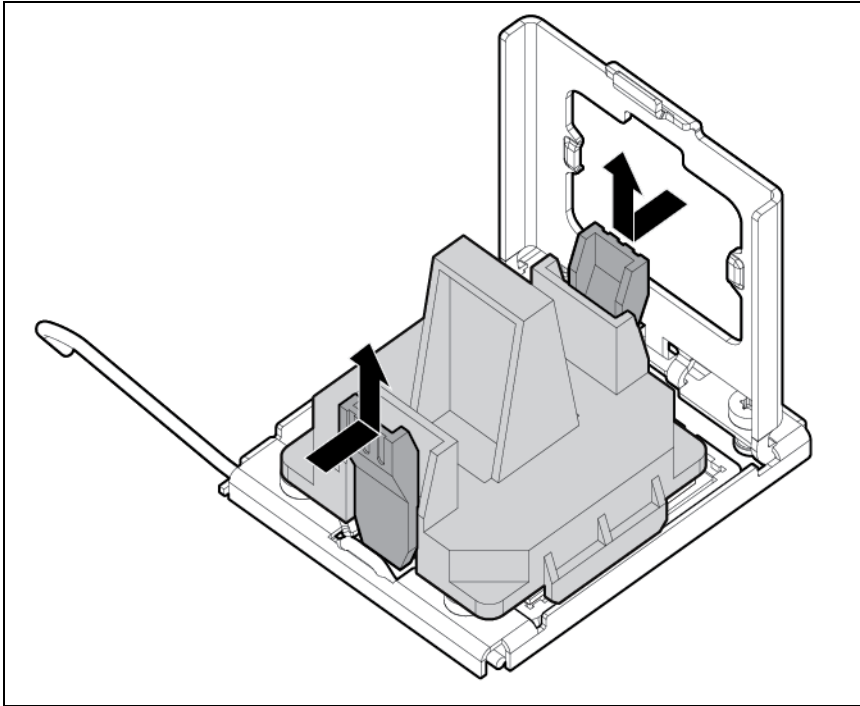

4. Close the processor socket retaining bracket and the processor locking lever.

△ CAUTION: Be sure to close the processor socket retaining bracket before closing the processor locking lever. The lever should close without resistance. Forcing the lever closed can damage the processor and socket, requiring system board replacement.

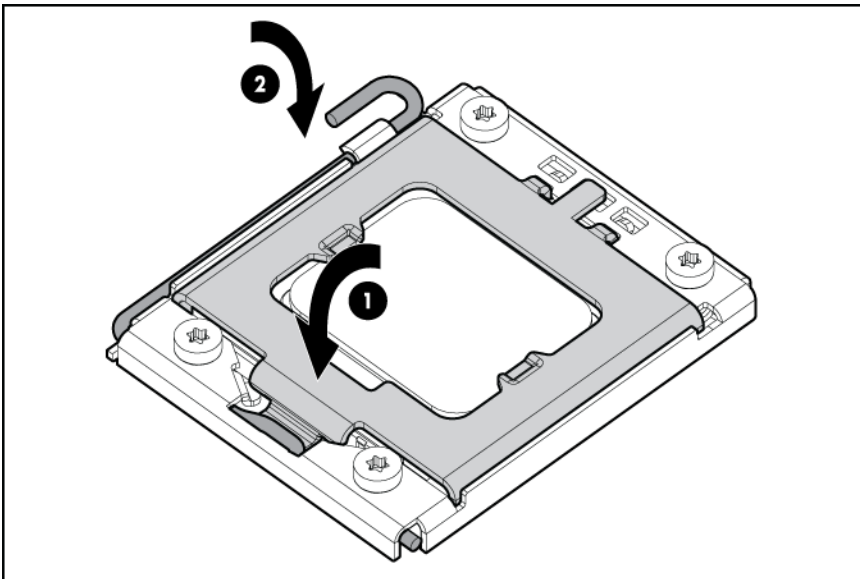

△ CAUTION: To allow heat sink to draw as much heat as possible from the processor base, there must be good contact between the heat sink base and the top of the processor. To ensure good contact, you must apply thermal interface material.

To apply thermal compound:

Perform the procedure below only if you will be using the same heat sink as before. If you are using a new one, there is no need to apply thermal compound as there is already a preapplied thermal compound in a new heat sink.

△ **CAUTION:** Applying too little thermal compound will cause a gap between the contact surfaces. This means that the heat sink is not even in direct contact with the processor, and therefore its capacity to draw out heat is greatly reduced. Furthermore, applying too much compound can make it squish out from the sides and go all over the processor pins or to the system board when the heat sink is installed. The compound may cause electrical shorts that can damage the system.

1. Use the alcohol pad (included in the new processor spare kit) to clean the contact surfaces on the heat sink and the new processor. Wipe the contact surfaces several times to make sure that no particles or dust contaminants are evident. Allow the alcohol to evaporate before continuing.

△ **CAUTION:** Do not touch the contact surfaces as this may leave dead skin cells or oils from your finger that can result in poor thermal compound performance.

2. Apply 0.5 gram (0.25 ml) of the thermal compound evenly onto the top of the processor. The figure below shows the correct pattern of applying the thermal compound.

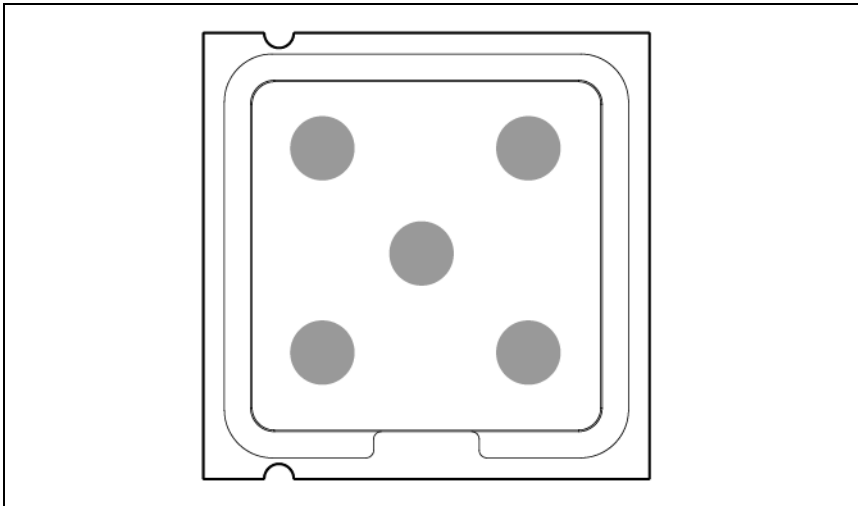

To install the heat sink:

CAUTION: To prevent overheating or a possible system crash, use only a heat sink specified for your ProLiant server.

1. If you are using a new heat sink, remove the cover protecting the preapplied thermal compound. Be careful not to touch or scratch the thermal compound.

IMPORTANT: Make sure the heat sink cable is not caught underneath the heat sink during installation.

2. Install the heat sink.
 - a. Insert the spring-loaded screws into the system board holes **(1)**.
 - b. Use a T-15 Torx screwdriver to tighten the spring-loaded screws **(2)**.
 - c. Connect the heat sink cable to its system board connector **(3)**.

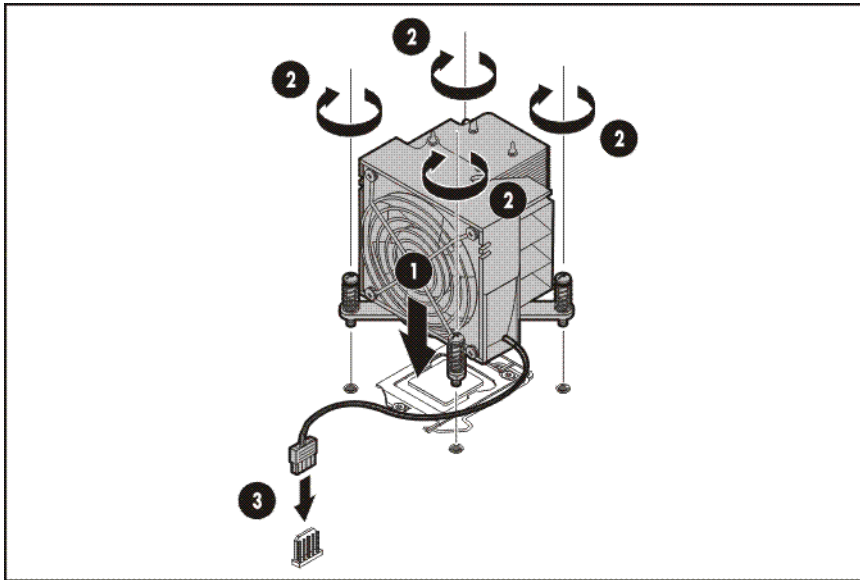

3. Perform the post-installation procedure.

Memory

The system has four DIMM slots that support PC3-10600E unbuffered DIMM (UDIMM) with ECC support. The DIMM slots are divided into two channels of two DIMM slots each.

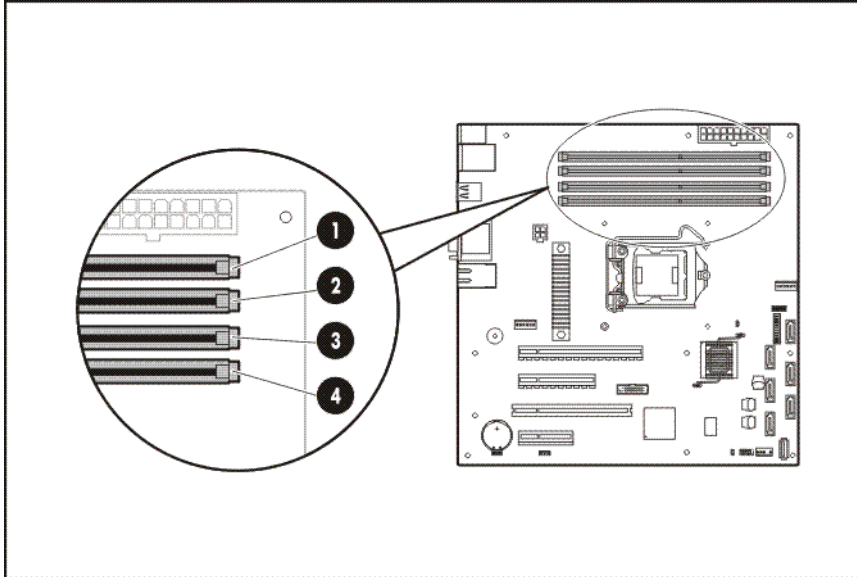

Item	Connector code	Slot type
1	DIMM4B	Channel B 1 st DDR3 DIMM slot
2	DIMM3D	Channel B 2 nd DDR3 DIMM slot
3	DIMM2A	Channel A 1 st DDR3 DIMM slot
4	DIMM1C	Channel A 2 nd DDR3 DIMM slot

Memory installation guidelines

Observe the following important guidelines when installing memory modules:

- Use only HP supported PC3-10600E UDIMM in 1 GB, 2 GB, or 4 GB capacities.
- Supported DIMM configurations include:
 - Single DIMM (non-interleaving) – It must be installed in the DIMM2A slot.

NOTE: To allow an interleaving memory configuration, the **Memory Interleaving** field in the **Advanced | Advanced Chipset Control** menu of the BIOS Setup must be set to **Enabled**.

- Two DIMMs (interleaving) – For optimum memory performance, install in the DIMM2A and DIMM4B slots.
- Four DIMMs
- When modules of varying speed are installed, the system will run at the fastest common frequency as determined through the SPD registers on the memory modules.

△ **CAUTION:** DIMMs can be damaged by improper handling. Always use an anti-static wrist strap and grounding mat, and discharge static electricity before touching DIMMs.

To install a memory module:

1. Perform the pre-installation procedure.
2. Lay the server on its side (components showing).
3. Locate an empty DIMM slot on the system board.
4. If necessary, open the holding clips of the selected DIMM slot.
5. Remove the memory module from its protective packaging, handling it by the edges.
6. Install the memory module.
 - a. Use both hands to hold the module by the edges, and then insert it perpendicularly into the slot (1).

The DIMM slots are structured to ensure proper installation. If you insert a memory module but it does not fit easily into the slot, you may have inserted it incorrectly. Reverse the orientation of the module and insert it again.

- b. Press the module at both ends to seat it fully into the slot (2).

The holding clips will automatically lock into place once the module has been seated properly.

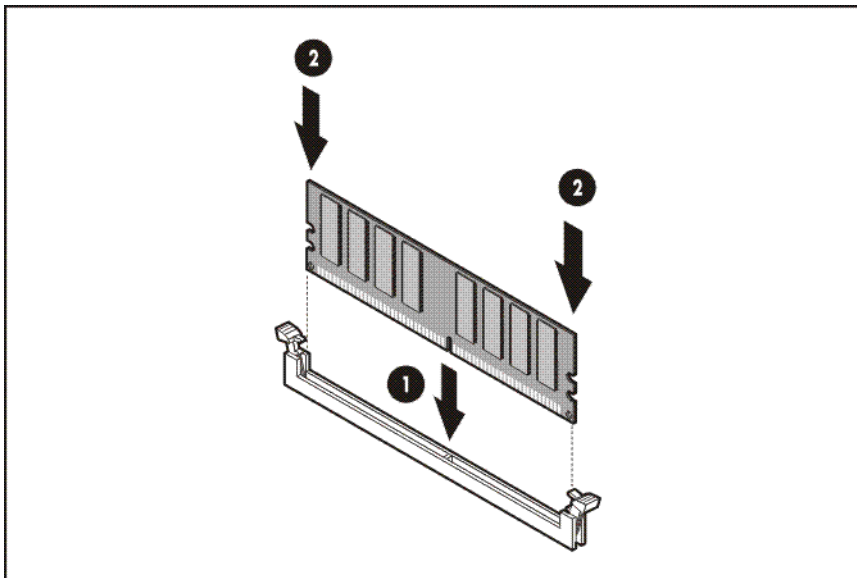

7. Perform the post-installation procedure.

Expansion board

Your ProLiant server has four expansion slots with four separate bus channels.

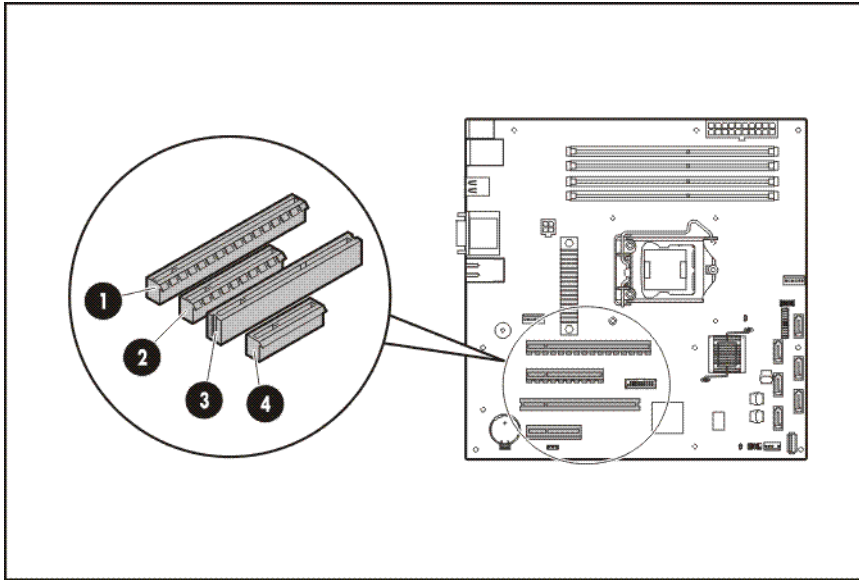

Item	Connector code	Slot type
1	Full-height full-length Slot 4 PCIe x16 (16) 45W	Full-height/full-length PCIe Gen2 x16 slot (x16)
2	Full-height full-length Slot 3 PCIe x8 (4) 25W	Full-height/full-length PCIe Gen1 x8 slot (x4)
3	Full-height full-length Slot 2 PCI 32-bit 33 MHz 25W	Full-height/full-length 32-bit/33 MHz PCI slot
4	Full-height half-length Slot 1 PCIe x4 (1) 25W	Full-height/half-length PCIe Gen1 x4 slot (x1)

To install an expansion board:

1. Perform the pre-installation procedure.
2. Prepare the system for the expansion board installation.
 - a. Loosen the expansion slot cover retainer thumbscrew (1).
 - b. Detach the expansion slot cover retainer from the chassis (2).

- c. Identify the slot that is compatible with the expansion board you intend to install, and then pull out its slot cover (3).
Store it for reassembly later.

⚠ CAUTION: Do not discard the slot cover. If the expansion board is removed in the future, the slot cover must be reinstated to maintain proper cooling

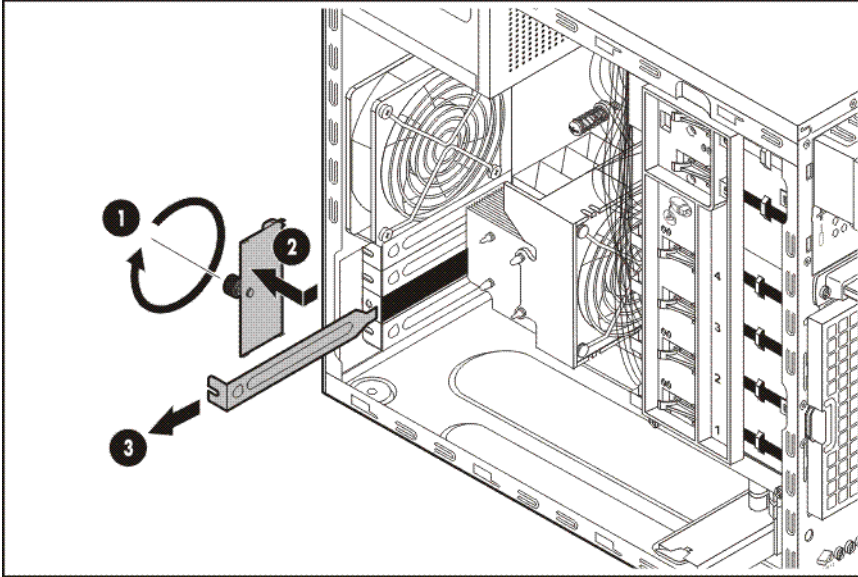

3. Remove the expansion board from its protective packaging, handling it by the edges.
4. Install the expansion board.
 - a. Slide the expansion board into the selected slot, and then press it down to seat it properly (1).
 - b. Slide the expansion slot cover retainer toward the slots covers (2).
 - c. Tighten the expansion slot cover retainer thumbscrew (3).

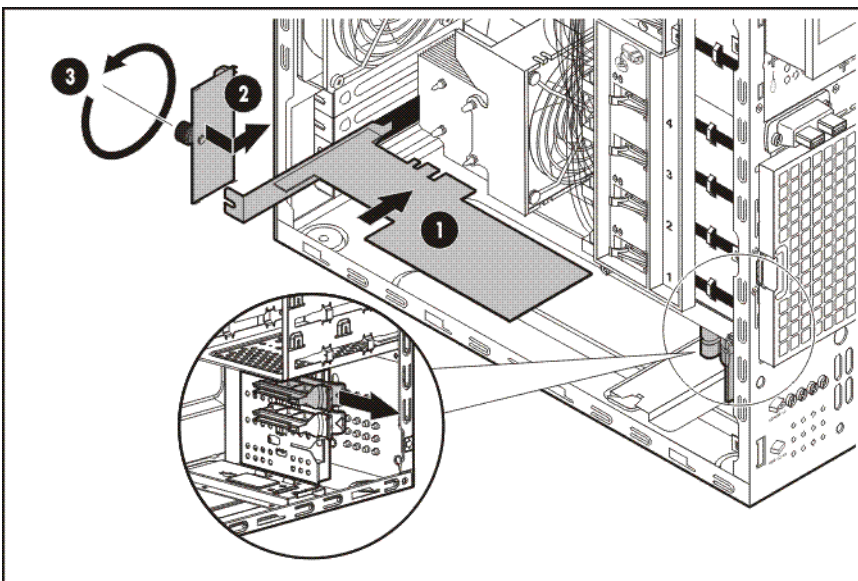

NOTE: For a full-length expansion board installation: Remove the full-length card retainer first (see the zoomed in section in the step 4 figure) opposite the expansion slot you are using and secure the board in it, and then install the board in the slot.

- d. Connect the necessary cables to the board.
Refer to the documentation that came with the board.
5. Perform the post-installation procedure.

SAS controller board option kit

If you intend to change the hard drives from a SATA to SAS configuration, install the SAS controller board first, and then connect the SAS HDD and LED cables. If you also have the SAS cache battery option kit, attach the SAS cache board to the SAS controller board first.

NOTE: Remove the SATA HDD cables from the chassis if you intend to switch to a SAS HDD configuration.

To install the SAS cache board:

1. Insert the SAS cache board into its connector on the bottom side of the SAS controller board.
Make sure the board is properly seated in the slot.
2. Close the holding clips to secure the board in place.

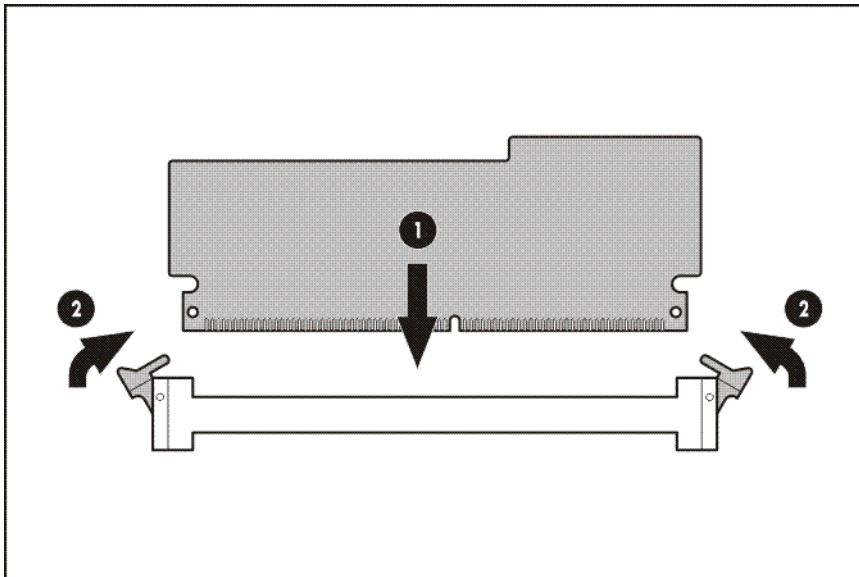

To install the SAS controller board:

1. Perform steps 1 and 2 of the “To install an expansion board” section.
2. Remove the SAS controller board from its protective packaging, handling it by the edges.
3. Install the SAS controller board.

It is recommended that the SAS controller board be installed in the full-height/full-length PCIe Gen1 x8 expansion slot.

- a. Slide the SAS controller board into the expansion slot, and then press it down to seat it properly (1).
- b. Slide the expansion slot cover retainer toward the slots covers (2).
- c. Tighten the expansion slot cover retainer thumbscrew (3).
- d. Connect the SAS cable master connector to the SAS controller board (4).
- e. Connect the SAS LED cable to the to the SAS controller board (5).

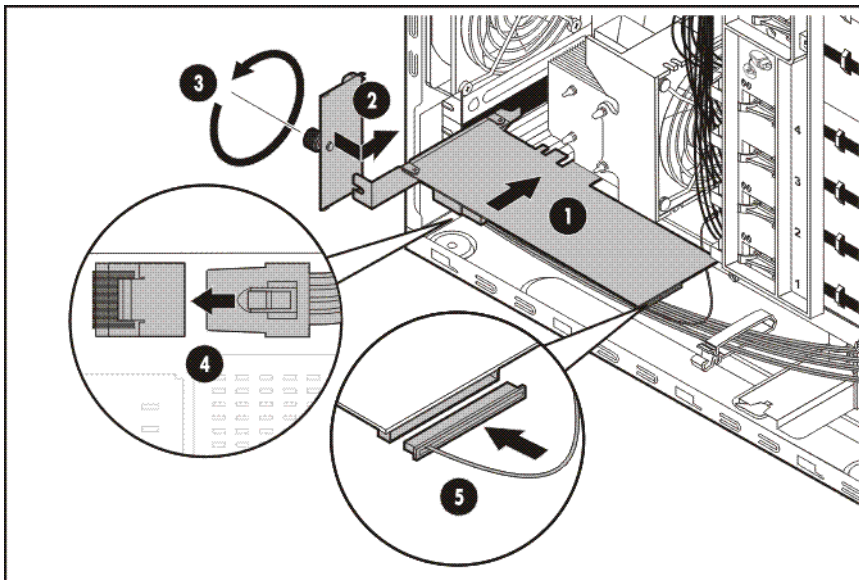

- f. Connect the SAS LED cable to the HDDLEDCN1 connector on the system board (6).

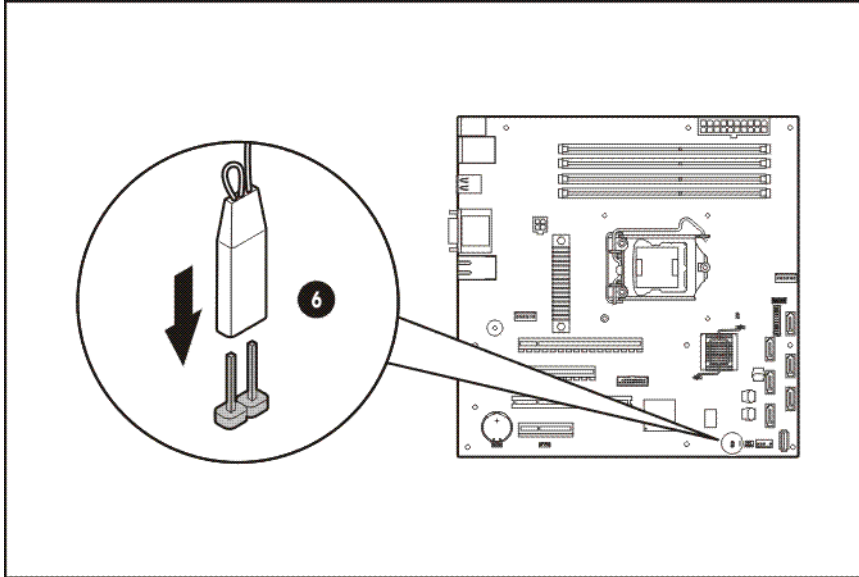

- g. Secure the SAS HDD and LED cables in the cable clamp located on the chassis base.
4. If you will be using a SAS cache battery, proceed to the next section for instructions on how to install the SAS cache battery.
5. If not, proceed to [page 40](#) for instructions on how to install a SAS hard drive.

To install the SAS cache battery:

1. Connect the BBWC cable to the SAS cache battery.

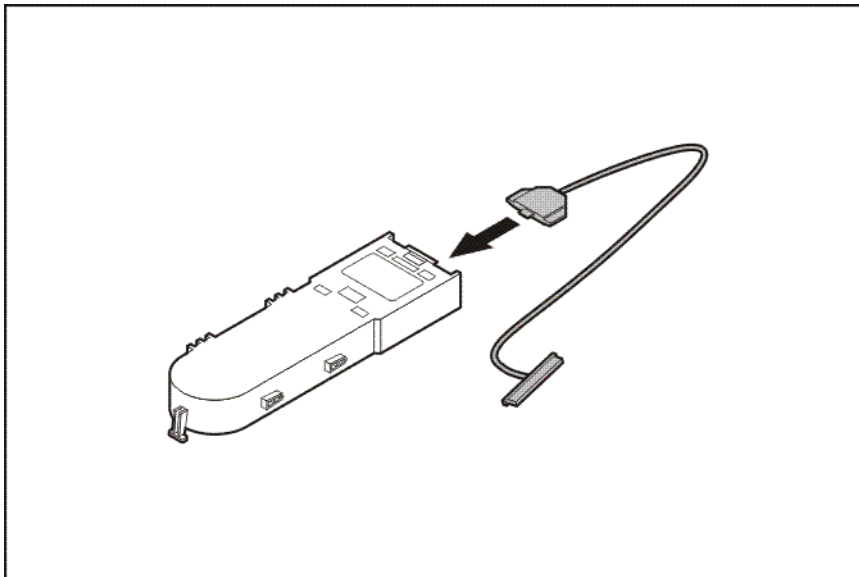

2. Install the SAS cache battery.
 - a. Mount the SAS cache battery on the chassis indentation located below the HDD cage (1).
 - b. Connect the BBWC cable to the SAS controller board (2).

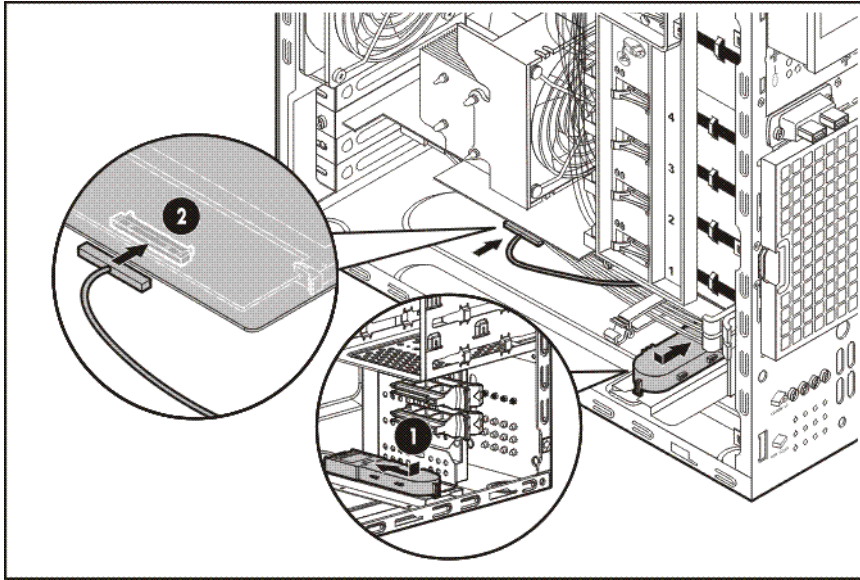

3. Proceed to page 40 for instructions on how to install a SAS hard drive.

Flash-backed write cache procedures

Two types of procedures are provided for the FBWC option:

- Removal and replacement of failed components:
 - Removing the cache module
 - Removing the capacitor pack
- Recovery of cached data from a failed server

△ **CAUTION:** Do not detach the cable that connects the battery pack to the cache module. Detaching the cable causes any unsaved data in the cache module to be lost.

Flash-backed write cache module

To remove the component:

△ **CAUTION:** Do not use this controller with cache modules designed for other controller models, because the controller can malfunction and you can lose data. Also, do not transfer this cache module to a different controller module, because you can lose data.

1. Back up all data.
2. Close all applications.
3. Power down the server.

CAUTION: In systems that use external data storage, be sure that the server is the first unit to be powered down and the last to be powered back up. Taking this precaution ensures that the system does not erroneously mark the drives as failed when the server is powered up.

4. Extend the server from the rack.
5. Remove the access panel.
6. If the existing cache module is connected to a capacitor pack, observe the FBWC module LEDs:
 - If the amber LED is flashing, data is trapped in the cache. Restore system power, and restart this procedure from step 1.
 - If the amber LED is not lit, remove the controller from the server, and then continue with the next step.
7. Open the ejector latches on each side of the DIMM slot. Normally, the cache module is ejected from the DIMM slot. If the module is not ejected automatically, remove the cache module.

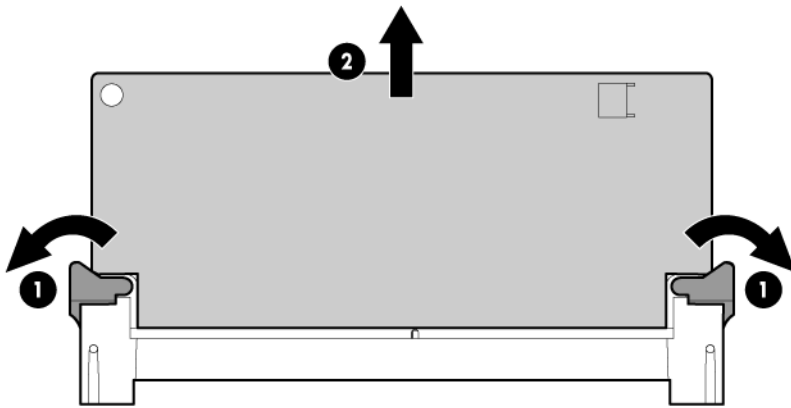

8. If the cache module is connected to a capacitor pack, disconnect the capacitor pack cable from the connector on the top of the cache module.

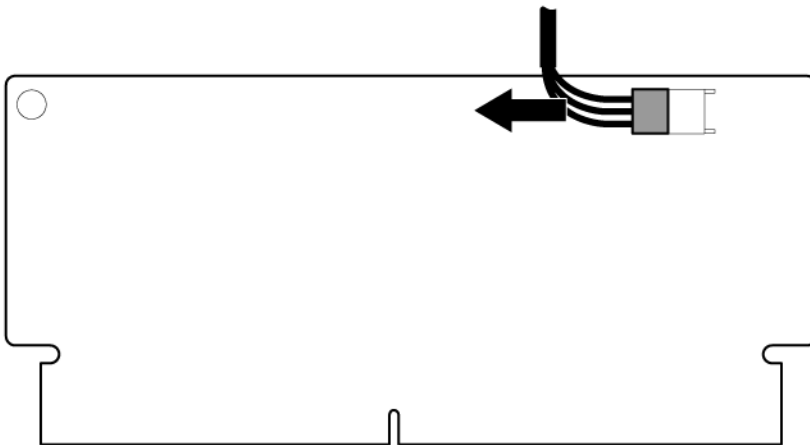

To replace the component:

CAUTION: To prevent damage to the cache module during installation, be sure the cache module is fully inserted before pressing down.

△ **CAUTION:** Do not use this controller with cache modules designed for other controller models, because the controller can malfunction and you can lose data. Also, do not transfer this cache module to a different controller module, because you can lose data.

1. Back up all data.
2. Close all applications.
3. Power down the server.

△ **CAUTION:** In systems that use external data storage, be sure that the server is the first unit to be powered down and the last to be powered back up. Taking this precaution ensures that the system does not erroneously mark the drives as failed when the server is powered up.

4. For ML110 G6 servers, extend the server from the rack.
5. For ML150 G6 servers, do one of the following:
 - Unlock and remove the bezel.
 - Extend the server from the rack.
6. Remove the access panel.
7. Install the storage controller, if not installed.
8. Connect the capacitor pack cable to the connector on the top of the cache module.

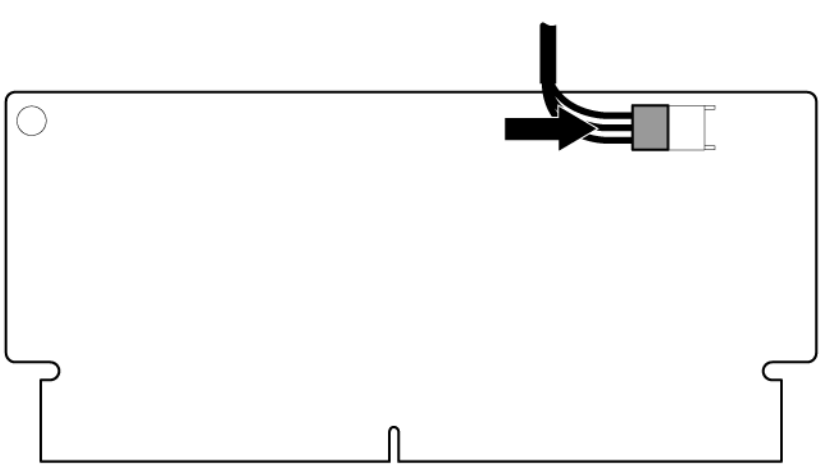

9. Install the cache module.

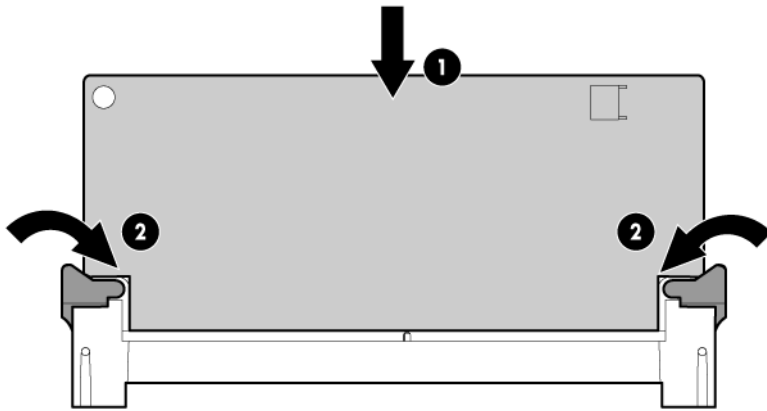

10. Install the capacitor pack.

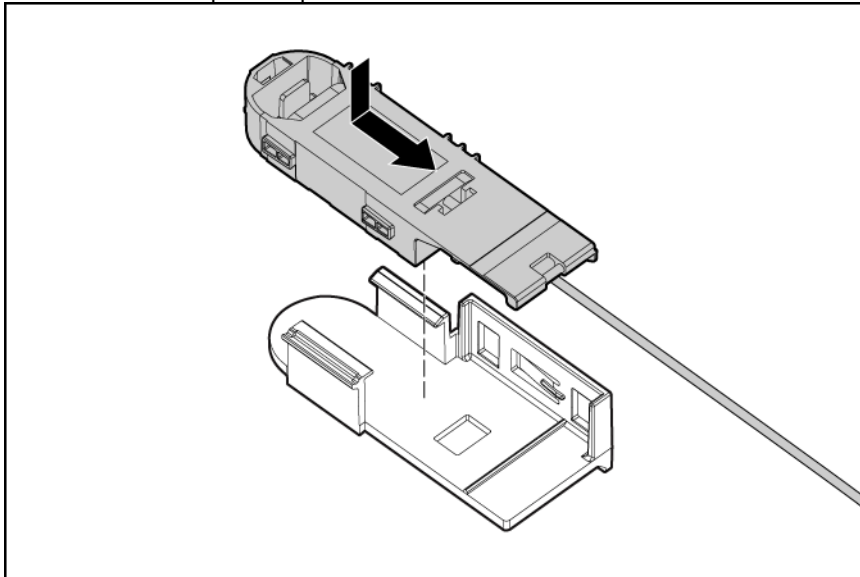

11. Route the cable.
12. Install the access panel.
13. For ML110 G6 servers, slide the server back into the rack.
14. For ML150 G6 servers, do one of the following:
 - Close or install the tower bezel, as needed.
 - Slide the server back into the rack.
15. Power up the server.

Flash-backed write cache capacitor pack

To remove the component:

1. Back up all data.
2. Close all applications.
3. Power down the server.

CAUTION: In systems that use external data storage, be sure that the server is the first unit to be powered down and the last to be powered back up. Taking this precaution ensures that the system does not erroneously mark the drives as failed when the server is powered up.

4. Extend the server from the rack.
5. Remove the access panel.
6. If the capacitor pack is connected to the cache module, disconnect the capacitor pack cable from the connector on the top of the cache module.

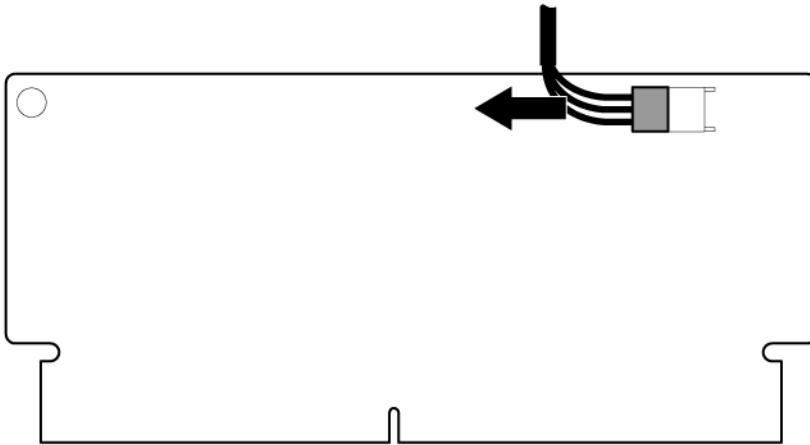

7. Disconnect the capacitor pack from the air baffle.

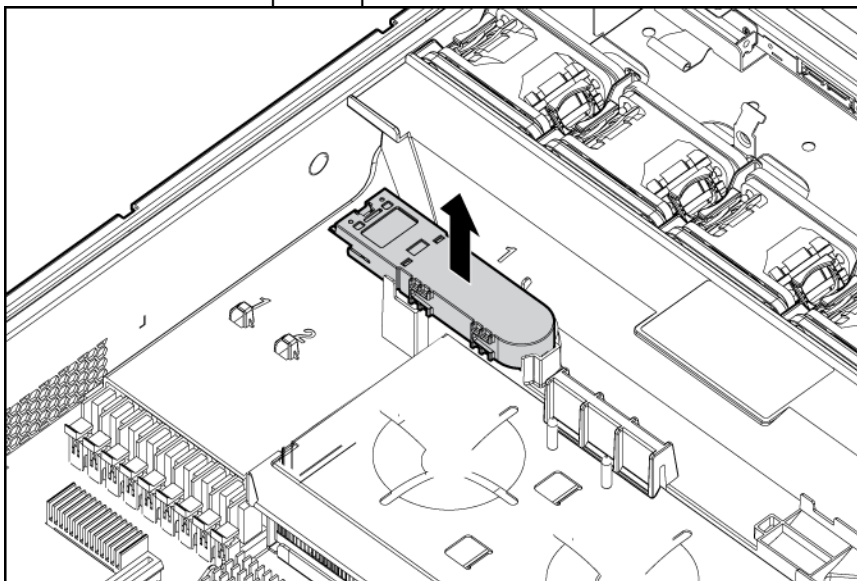

To replace the component, reverse the removal procedure.

System battery

The server uses a nonvolatile memory that requires a battery to retain system information when power is removed. This 3-volt 200-mAh lithium coin cell RTC battery is located on the system board.

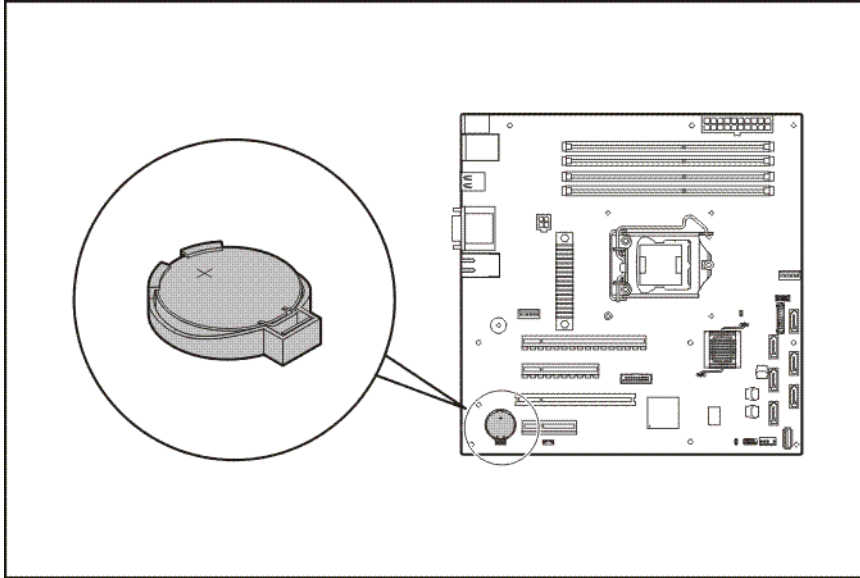

If the server no longer automatically displays the correct date and time, the system battery that provides power to the real-time clock may need to be replaced. Under normal use, battery life is 5 to 10 years.

System battery replacement warnings

Observe the following reminders when replacing the system battery:

- Replace the battery with the same type as the battery recommended by HP. Use of another battery may present a risk of fire or explosion.
- A risk of fire and chemical burn exists if the battery is not handled properly. Do not disassemble, crush, puncture, or short external contacts, or expose the battery to temperatures higher than 60 °C (140 °F).
- Do not dispose of used battery in water or fire. Dispose of used batteries according to manufacturer's instructions.
- Loss of BIOS settings occurs when the battery is removed. BIOS settings must be reconfigured whenever the battery is replaced.

To replace the system battery:

1. Perform the pre-installation procedure.
2. Lay the server on its side (components showing).
3. If necessary, remove any accessory boards or cables that prevent access to the battery socket.
4. Locate the system battery.
5. Replace the system battery.

 **IMPORTANT:** Do not bend the spring latch when replacing the RTC battery. For proper operation, the latch must retain contact with the battery.

- a. Insert a small flat-blade screwdriver between the battery and spring latch to dislodge the battery from its socket (1).
- b. Remove the old battery from its socket (2).

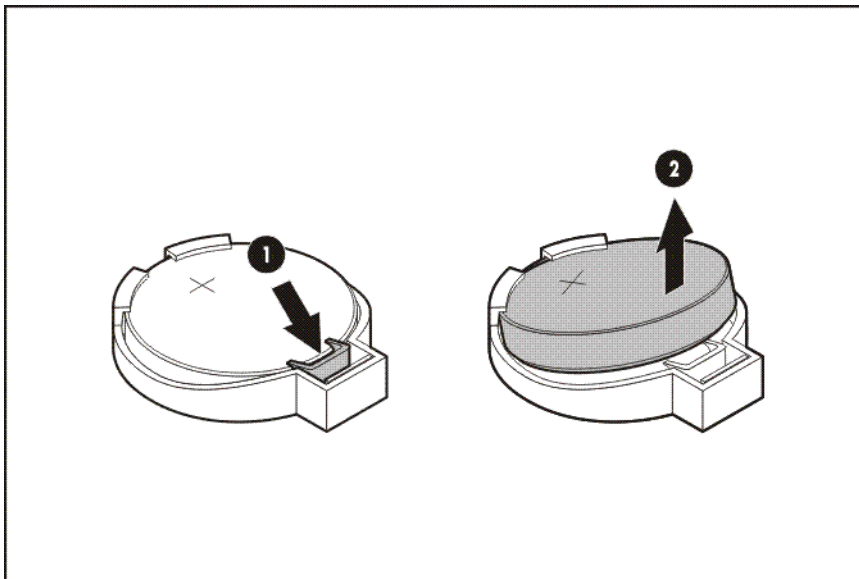

6. Remove the new system battery from its protective packaging.
7. Install the new system battery.
 - a. Slide one edge of the replacement battery under the holder lip with the positive side facing up (1).

- b. Push the other edge down until the clamp snaps over the battery (2).

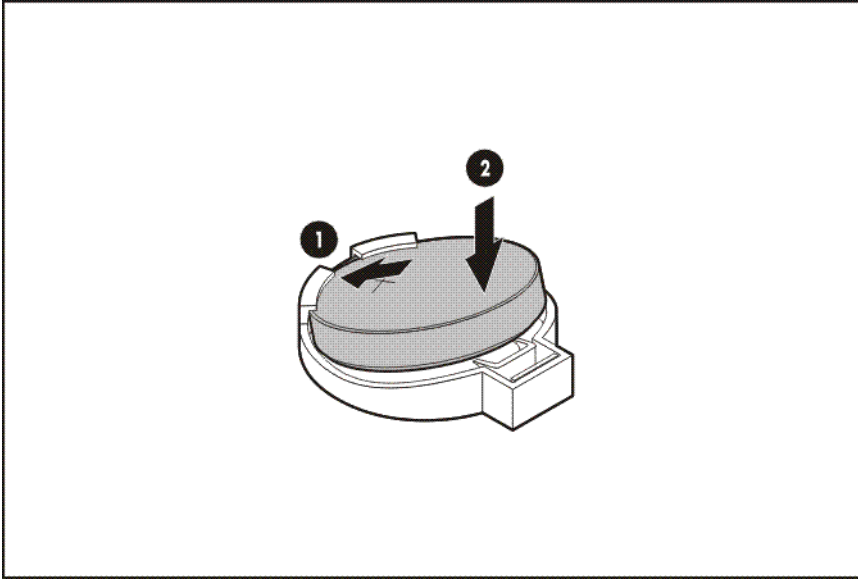

8. Perform the post-installation procedure.

System fan

A new system fan can be installed to allow the server to operate properly in case the default system fan becomes defective.

To replace the system fan:

⚠ CAUTION: Be sure to support the system fan with your hand when removing screws from the chassis. The fan could fall onto the system board or an accessory board causing damage if not supported.

1. Perform the pre-installation procedure.
2. Remove the default system fan:
 - a. Disconnect the system fan cable from its system board connector (1).
 - b. From inside the chassis, slightly detach the fan from the chassis, and then pull the four rubber bolts through their chassis holes (2).
 - c. Remove the fan from the chassis (3).

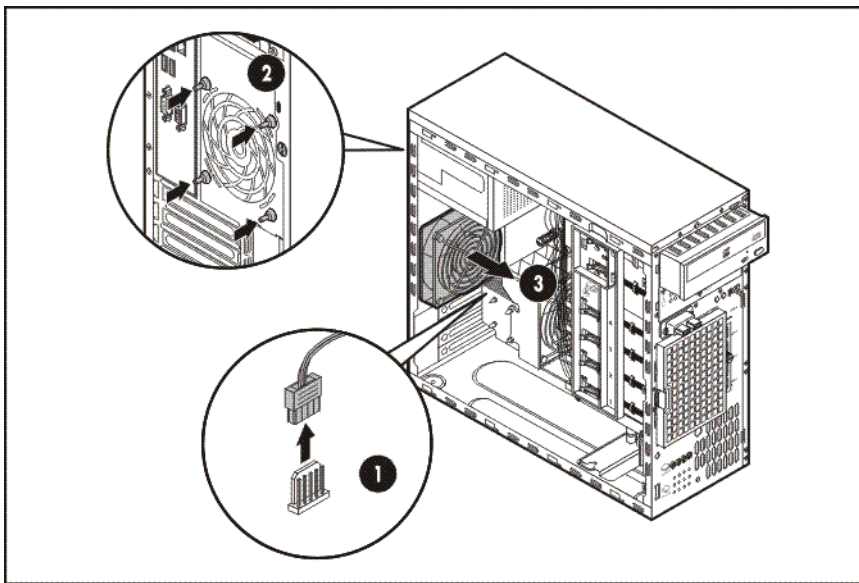

3. Remove the new system fan from its protective packaging.

4. Install the new system fan.
 - a. Align the rubber bolts to their chassis holes (1).
 - b. While holding the new fan against the chassis, pull the rubber bolts through their chassis holes (2).

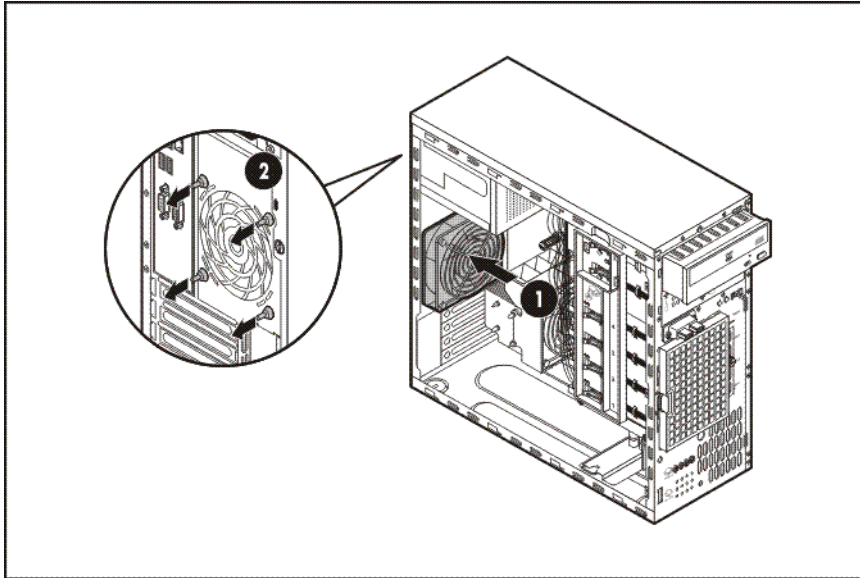

- c. Connect the system fan cable to its system board connector (3).

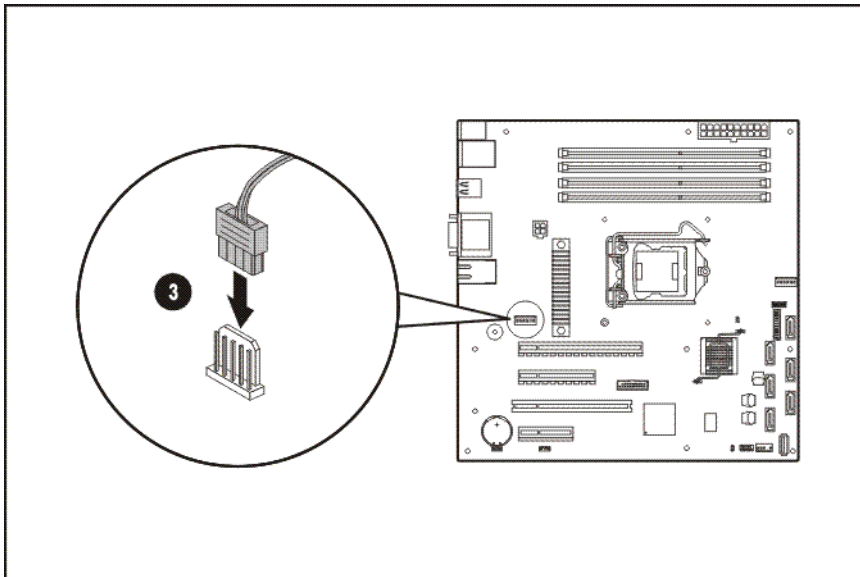

5. Perform the post-installation procedure.

Power supply unit

Located on the rear panel of the server is a single standard autoranging 300W power supply unit (PSU).

PSU replacement warnings

Observe the following reminders to reduce the risk of personal injury from electric shock hazards and/or damage to the equipment

- Installation of the power supply unit should be referred to individuals who are qualified to service server systems and are trained to deal with equipment capable of generating hazardous energy levels.
- DO NOT open the power supply unit. There are no serviceable parts inside it.

To replace the power supply unit:

1. Perform the pre-installation procedure.
2. Remove the default power supply unit.
 - a. Disconnect the power cables from the system board (1).
Disconnect the power cables from the system drives.
See [page 36](#) for an illustration of these cable connections.
 - b. While supporting the power supply unit with one hand, remove the four PSU screws from the rear panel (2).
 - c. Remove the power supply unit from the chassis (3).

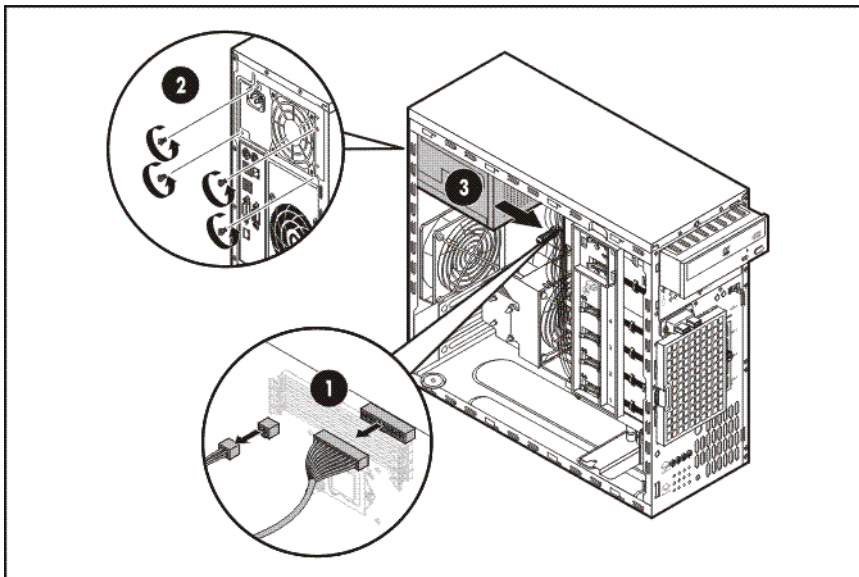

3. Install the new power supply unit.
 - a. Align the new power supply unit inside the chassis (1).
 - b. Secure the power supply unit to the chassis using the four screws you removed in step 2-b (2).
 - c. Reconnect the system power cables you removed in step 2-a (3).

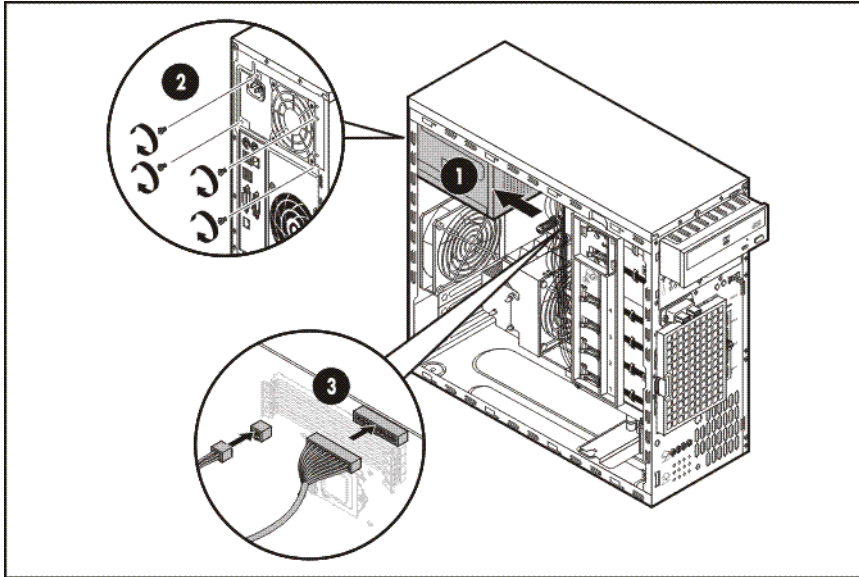

4. Perform the post-installation procedure.

Diagnostics tools

Troubleshooting resources

NOTE: For common troubleshooting procedures, the term "server" is used to mean servers and server blades.

The *HP ProLiant Servers Troubleshooting Guide* provides simple procedures for resolving common problems as well as a comprehensive course of action for fault isolation and identification, error message interpretation, issue resolution, and software maintenance.

To obtain the guide, refer to any of the following sources and then select the *HP ProLiant Servers Troubleshooting Guide*:

- The server-specific Documentation CD
- The Business Support Center on the HP website (<http://www.hp.com/support>). Navigate to the server technical support page. Under self-help resources, select **ProLiant Troubleshooting Guide**.
- The Technical Documentation website (<http://www.docs.hp.com>). Select **Enterprise Servers, Workstations and Systems Hardware**, and then the appropriate server.

HP Insight Diagnostics

HP Insight Diagnostics is a proactive server management tool, available in both offline and online versions, that provides diagnostics and troubleshooting capabilities to assist IT administrators who verify server installations, troubleshoot problems, and perform repair validation.

HP Insight Diagnostics Offline Edition performs various in-depth system and component testing while the OS is not running. To run this utility, launch the *Easy Set-up CD*.

HP Insight Diagnostics Online Edition is a web-based application that captures system configuration and other related data needed for effective server management. Available in Microsoft® Windows® and Linux versions, the utility helps to ensure proper system operation.

For more information or to download the utility, refer to the HP website (<http://www.hp.com/servers/diags>).

Survey Utility

Survey Utility, a feature within HP Insight Diagnostics, gathers critical hardware and software information on ProLiant servers.

This utility supports operating systems that may not be supported by the server. For operating systems supported by the server, refer to the HP website (<http://www.hp.com/go/supportos>).

If a significant change occurs between data-gathering intervals, the Survey Utility marks the previous information and overwrites the Survey text files to reflect the latest changes in the configuration.

Array Diagnostic Utility

The HP Array Diagnostics Utility is a web-based application that creates a report of all HP storage controllers and disk drives. This report provides vital information to assist in identifying faults or conditions that may require attention. ADU can be downloaded from the HP website (<http://www.hp.com>).

HP Instant Support Enterprise Edition

ISEE is a proactive remote monitoring and diagnostic tool to help manage your systems and devices, a feature of HP support. ISEE provides continuous hardware event monitoring and automated notification to identify and prevent potential critical problems. Through remote diagnostic scripts and vital system configuration information collected about your systems, ISEE enables fast restoration of your systems. Install ISEE on your systems to help mitigate risk and prevent potential critical problems.

For more information on ISEE, refer to the HP website (http://www.hp.com/hps/hardware/hw_enterprise.html).

To download HP ISEE, visit the HP website (http://www.hp.com/hps/hardware/hw_downloads.html).

For installation information, refer to the HP ISEE Client Installation and Upgrade Guide (ftp://ftp.hp.com/pub/services/hardware/info/isee_client.pdf).

Web-Based Enterprise Service

WEBES enables administrators to manage hardware events proactively, either locally or online. The service provides real-time multiple event analysis, crash analysis, and notification, locally through SMTP and remotely through ISEE for OpenVMS, Tru64, and Microsoft Windows operating system binary error logs.

For more information, refer to the HP website (<http://h18000.www1.hp.com/support/svctools/>).

Open Services Event Manager

OSEM is a standalone tool that performs real-time reactive and proactive service event filtering, analysis, and notification. The tool gathers event data from SNMP traps or information provided over an HTTP interface and notifies an administrator or HP through SMTP and ISEE.

For more information, refer to the HP website (<http://h18000.www1.hp.com/support/svctools/>).

Phoenix SecureCore BIOS software

Your ProLiant server uses BIOS to boot up the system. The Phoenix SecureCore BIOS software is a ROM BIOS-based firmware that allows reliability, manageability, and connectivity for server platforms. This software contains a set of programs permanently stored in an EEPROM chipset located on the system board. These programs assist in managing, initializing, and testing the hardware devices installed on the computer.

The Phoenix SecureCore software serves three functions:

- Configure the system from the Phoenix SecureCore Setup Utility
Using the Setup program, you can install, configure, and optimize the hardware devices on your system (clock, memory, disk drives, etc.). In addition, you can enable various features such as serial console redirection, PXE boot, and much more.
- Initialize hardware at boot using POST routines
During power-on or warm reset, the software performs Power-On Self-Test (POST) routines to test components, to allocate resource for various hardware devices, and to prepare the system to boot to various operating systems.
- Perform run-time routines
Using the software, perform basic hardware routines that can be called from DOS and Windows applications.

Configuring the system BIOS

NOTE: For ease of reading, Phoenix SecureCore Setup Utility will be simply referred to as “Setup” or “Setup Utility” in this guide. Also, the screenshots used in this guide display various Setup menu screens with the default values identified. These values may not be the same as those in your server.

Phoenix SecureCore Setup Utility is a hardware configuration program built into your system's Basic Input/Output System (BIOS). Since most systems are already properly configured and optimized, there is normally no need to run this utility.

You will need to run this utility under the following conditions:

- When changing the system configuration including:
 - Setting the system time and date
 - Configuring the hard drives
 - Specifying the boot device sequence

- Installing PCI expansion boards
- Upgrading the system BIOS
- Configuring the power management modes
- Setting up system passwords or making other changes to the security setup
- When a configuration error is detected by the system and you are prompted (Run Setup message) to make changes to the BIOS settings.

NOTE: If you repeatedly receive Run Setup messages, the system battery may be defective. In this case, the system cannot retain configuration values in CMOS. Replace the system battery with a new one.

The Setup Utility loads the configuration values in a battery-backed nonvolatile memory called CMOS RAM. This memory area is not part of the system RAM, which allows configuration data to be retained when power is turned off. The values take effect when the system is booted. POST uses these values to configure the hardware. If the values and the actual hardware do not agree, POST generates an error message. You must run this utility to change the BIOS settings from the default or current configuration.

The Setup Utility has five primary menu selections, including:

- Main
- Advanced
- Security
- Boot
- Exit

To run the Setup Utility:

1. Turn on the monitor and the server.

If the server is already turned on, save your data and exit all open applications, and then restart the server.

2. During POST, press **F10**.

If you fail to press **F10** before POST is completed, you will need to restart the server.

The first page to be displayed will be the **Main** menu showing the Setup Utility menu bar. Use the left (←) and right (→) arrow keys to move between selections on the menu bar.

Setup Utility navigation keys

Use the following keyboard keys to work your way through the various menu and submenu screens of the Setup Utility.

Key	Functions
← and →	To move between selections on the menu bar.
↑ and ↓	To move the cursor to the field you want. The currently selected field will be highlighted. The right side of each menu screen displays the Item Specific Help panel. This panel displays the help text for the currently selected field. It updates as you move the cursor to each field.
PgUp and PgDn	To move the cursor to the previous and next page of a multiple page menu.
Home	To move the cursor to the first page of a multiple page menu.
End	To move the cursor to the last page of a multiple page menu.
(+) , (-), and <Space>	To select a value for the currently selected field (only if it is user-configurable). Press the (+), (-), or <Space> keys repeatedly to display each possible entry, or the Enter key to choose from a pop-up menu. A parameter that is enclosed in square brackets [] is user-configurable. Grayed-out parameters are not user-configurable for one of the following reasons: <ul style="list-style-type: none">• The field value is auto-configured or auto-detected.• The field value is informational only.• The field is password-protected.
Enter	To select a field value or display more options for menu marked with ►.
Ctrl+Enter	To expand all device lists.
F1 or <Alt+H>	To bring up the General Help window. The General Help window describes other Setup navigation keys that are not displayed on the legend bar.
Esc or <Alt+X>	If you press this key: <ul style="list-style-type: none">• On one of the primary menu screens, the Exit menu displays.• On a submenu screen, the previous screen displays.• When you are making selections from a pop-up menu, closes the pop-up without making a selection.
F9	Loads the default system values.
F10	Saves changes and closes the Setup Utility.

Setup Utility menus

The Setup Utility provides a menu bar with the menu selections. The menu bar choices are described in the following sections.

Main menu

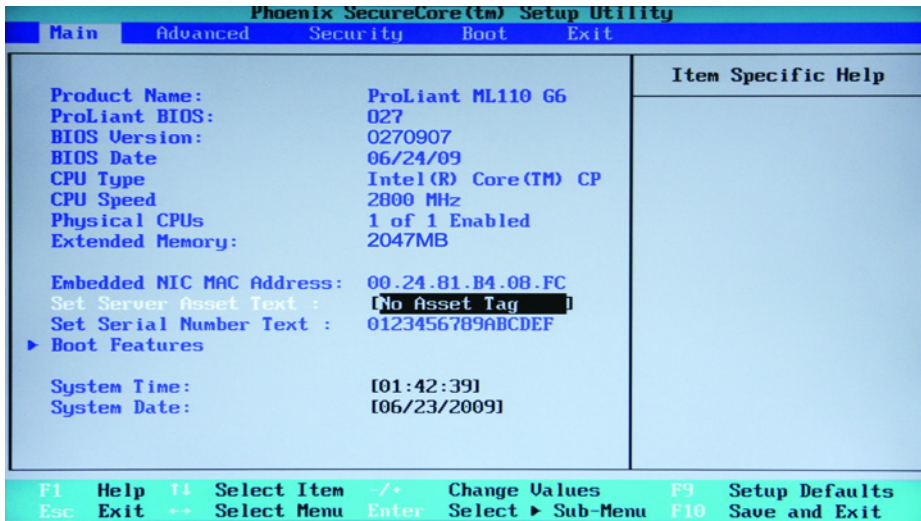

Field	Description
Product Name	Server model name
ProLiant BIOS	System BIOS revision number
BIOS Version	System BIOS version
BIOS Date	BIOS build date
CPU Type	Processor model name
CPU Speed	Processor speed
Physical CPUs	Number of installed processor
Extended Memory	Size of extended memory detected during bootup Extended memory = Total memory – 1MB
Embedded NIC MAC Address	MAC address of the embedded NIC
Set Server Asset Text	Enter the server asset tag and serial number. This information is printed on the serial label located on the rear panel.
Set Serial Number Text	
Boot Features	Set which options to run during system bootup. Press Enter to access the related submenu.
System Time	Adjust the system time.
System Date	Adjust the system date.

Boot Features submenu

Phoenix SecureCore (tm) Setup Utility		
Main		
Boot Features		Item Specific Help
Embedded VGA Control:	[Auto Detect]	Display the Splash screen during boot.
Summary screen:	[Enabled]	
NumLock:	[Enabled]	
POST F1 Prompt	[Delayed]	
Restore after AC Power Loss:	[Last State]	
Boot-time Diagnostic Screen:	[Disabled]	
POST Speed Up:	[Enabled]	
Splash Screen:	[Enabled]	
Extended Memory Testing	[None]	
Virtual Install Disk	[Enabled]	
Embedded NIC Port 1 PXE:	[Enabled]	
F1 Help ↑↓ Select Item -/+ Change Values F9 Setup Defaults Esc Exit ↔ Select Menu Enter Select ▶ Sub-Menu F10 Save and Exit		

Field	Description	Options
Embedded VGA Control	Select the status of the embedded graphics controller when an external VGA card is installed. <ul style="list-style-type: none"> • Auto Detect – Disable the embedded graphics controller when an external VGA card is installed. • Always Enabled – The embedded graphics controller remains the primary controller even if an external VGA card is installed. 	Auto Detect Always Enabled
Splash Screen	Enable this option to display the splash screen prior to loading the operating system. Disabling this option speeds up the boot process	Enabled Disabled
NumLock	Select the NumLock state when the server is powered on. <ul style="list-style-type: none"> • Enabled – NumLock is on. • Disabled – NumLock is off. • Auto – The NumLock state will be the same as it was when the server was last powered off. 	Enabled Disabled Auto
POST F1 Prompt	Select what action to take when a POST error occurs during bootup. <ul style="list-style-type: none"> • Delayed – The system pauses for about 5 seconds and then continues booting up. • Enabled – The system pauses and will only continue booting up when the F1 key is pressed. • Disabled – The system ignores any POST errors during bootup. 	Delayed Enabled Disabled
Restore After AC Power Loss	Select the power state when an AC power loss occurs. <ul style="list-style-type: none"> • Off – The server remains off until the power button is pressed. • Last State – The server reverts to the last power state before the power loss occurred. • On – The server switches back on after the AC power loss. 	Off Last State On
Splash Screen	Enable this option to display the splash screen during bootup.	Enabled Disabled

Field	Description	Options
POST Speed Up	Enable this option to skip certain POST routines and shortening others. This will decrease the time needed to boot up the system.	Enabled Disabled
Extended Memory Testing	Select the type of memory test to employ during bootup. <ul style="list-style-type: none"> None – Set the memory size based on previous boot. Just zero it – Quick boot, set memory size to zero. Normal – Full test, all test patterns written/read 	None Just zero it Normal
Virtual Install Disk	Select whether to enable access to the virtual install disk. The virtual install disk is a holding place within the system ROM that contains embedded boot drivers that may be necessary to complete the operating system installation.	Enabled Disabled
Embedded NIC Port 1 PXE	Enable this option to allow remote boot over LAN via the embedded NIC port.	Enabled Disabled

Advanced menu

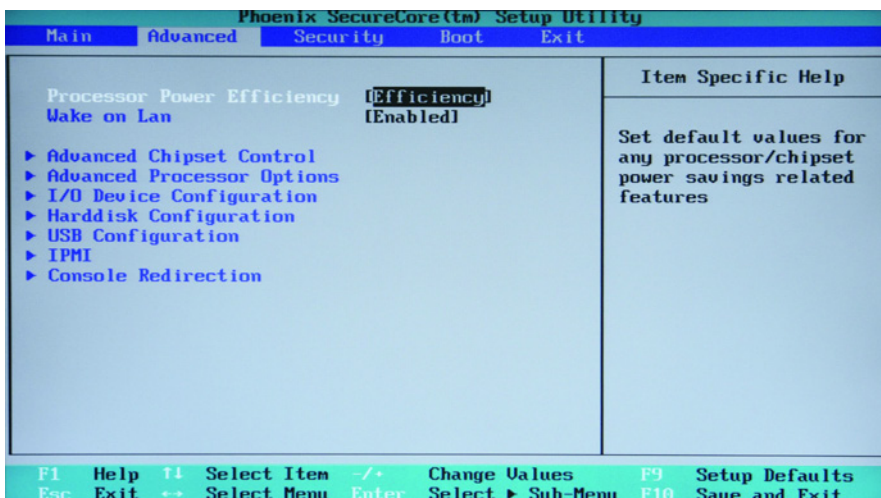

Field	Description	Options
Processor Power Efficiency	Select which processor power management profile to employ. <ul style="list-style-type: none"> Efficiency – Power-saving efficiency is prioritized. Performance – boosting system performance is prioritized. Custom – User-dependent power management profile. 	Efficiency Performance Custom
Wake on LAN	Enable this option to allow the server to be turned on or woken up remotely by another computer over the network. Note: After enabling WOL in BIOS Setup, you may be required to enable the WOL setting on your operating system as well before the WOL function can be employed. Consult your OS documentation for related instructions.	Enabled Disabled
Advanced Chipset Control	Displays the settings related to the system chipsets. Press Enter to access the related submenu.	
Advanced Processor Options	Displays the settings related to the processor. Press Enter to access the related submenu.	

Field	Description	Options
I/O Device Configuration	Displays the settings related to the serial port. Press Enter to access the related submenu.	
Hard Disk Configuration	Displays the settings related to the system hard drives. Press Enter to access the related submenu.	
USB Configuration	Displays the settings related to the USB function. Press Enter to access the related submenu.	
IPMI	Displays server management-related settings. Press Enter to access the related submenu.	
Console Redirection	Displays console redirection-related settings. Press Enter to access the related submenu.	

Advanced Chipset Control submenu

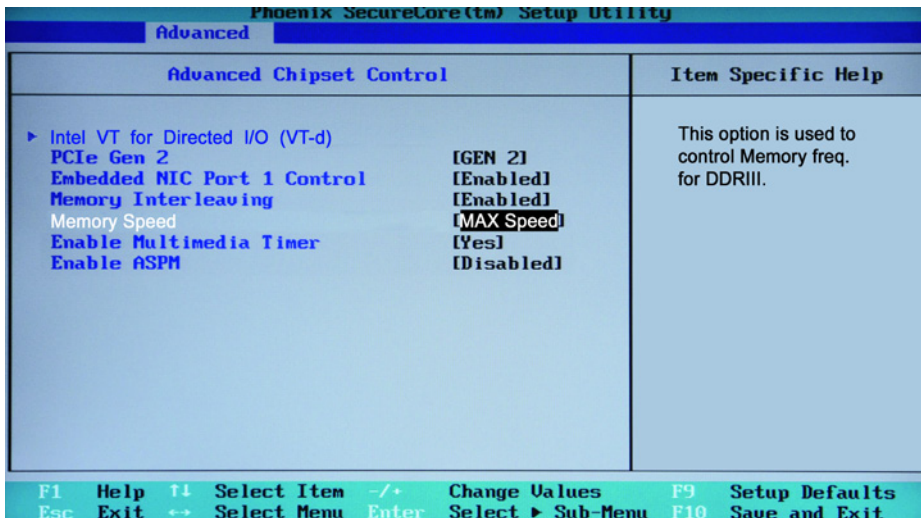

Field	Description	Options
Intel VT for Directed I/O (VT-d)	Press Enter to display Intel Virtualization Technology for Directed I/O screen which allows users to enable VT-d in the server.	
PCIe Gen 2	Select the operation mode of PCIe devices. <ul style="list-style-type: none"> Gen 1 – All PCIe devices will only run in Gen 1 mode (2.5 GT/s). Gen 2 – The system will detect the PCIe device generation and function accordingly. 	Gen 1 Gen 2
Embedded NIC Port 1 Control	Select whether to enable or disable the embedded NIC port.	Enabled Disabled
Memory Interleaving	Select whether to enable or disable a memory interleaving configuration.	Enabled Disabled
Memory Speed	Select the memory frequency setting. Memory frequency options will depend on the frequencies supported by the installed DIMMs.	Max Speed [supported DIMM frequencies]

Field	Description	Options
Enable Multimedia Timer	Select whether to enable or disable the High Precision Event Timer (HPET). When enabled, multimedia streams are better synchronized providing smoother playback. Note: This option must be enabled to allow Windows Vista installation.	Enabled Disabled
Enable ASPM	Select whether to enable or disable Active State Power Management (ASPM) in a Windows Vista environment. When enabled, Vista allows PCIe devices to function in a manner that will maximize power efficiency. Note: This option must be set to Disabled when a PCIe expansion card is installed to avoid system hang-ups.	Enabled Disabled

Intel VT for Directed I/O (VT-d) submenu

In a virtual setup, multiple operating systems and applications in independent partitions can run on a single server. When enabled, VT-d improves I/O performance and provides increased security through device isolation using hardware assisted remapping.

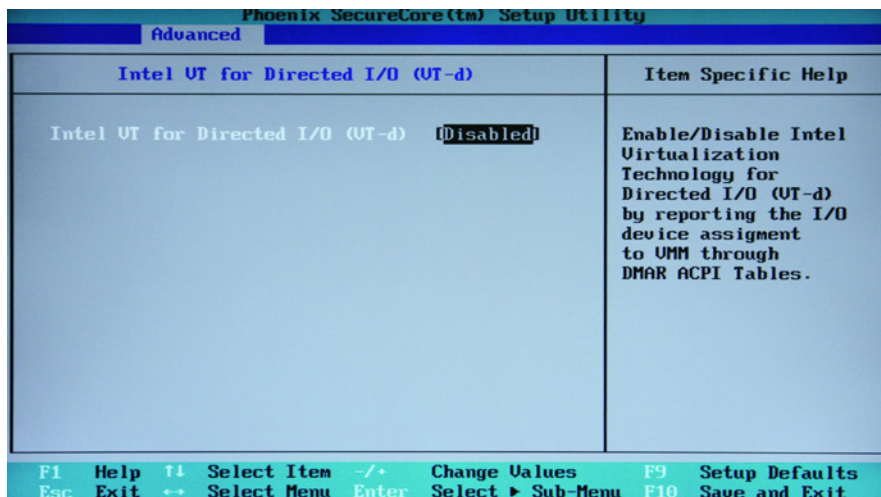

NOTES:

- Enable the **Intel Virtualization Technology** option in the **Advanced | Advanced Processor Options** submenu before enabling the VT-d function.
- After enabling VT-d in BIOS Setup, you need to enable it on your operating system as well. Consult your OS documentation for related instructions.

Advanced Processor Options submenu

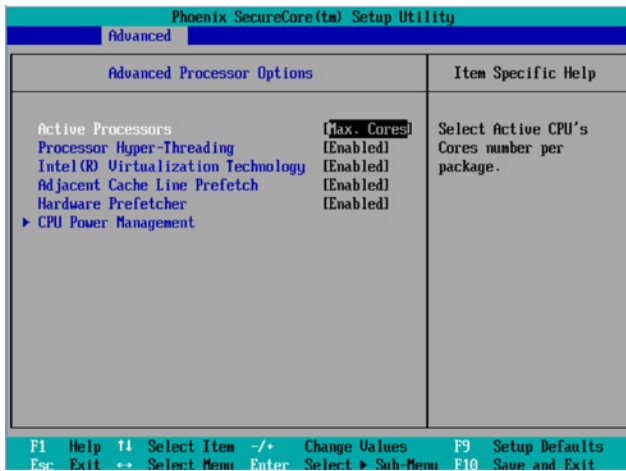

Field	Description	Options
Active Processor	Select the number of CPU cores to activate.	Max. Cores Two cores One core
Processor Hyper-Threading	Select whether to enable Intel Hyper-Threading (HT) Technology in your server. HT enables the host operating system to view a single physical processor to appear as two logical processors. This can boost performance in OS and applications that are HT-compliant.	Enabled Disabled
Intel Virtualization Technology	Select whether to enable Intel Virtualization Technology. VT allows a single platform to run multiple operating systems in independent partitions.	Enabled Disabled
Adjacent Cache Line Prefetch	When enabled, the processor will retrieve the currently requested cache line, as well as the subsequent cache line. When disabled, the processor will only retrieve the currently requested cache line.	Enabled Disabled
Hardware Prefetcher	When enabled, the processor's hardware prefetcher will be allowed to automatically prefetch data and code for the processor. This reduces the latency associated with memory reads.	Enabled Disabled
CPU Power Management	Press Enter to display the <i>CPU Power Management</i> screen and configure the processor power management scheme.	

CPU Power Management submenu

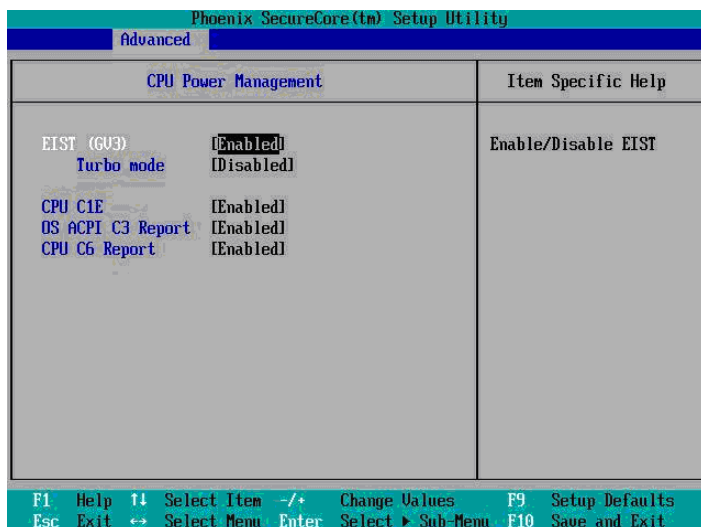

Field	Description	Options
EIST (GU3)	Select whether to enable Enhanced Intel SpeedStep Technology. EIST allows a compliant OS to dynamically adjust the processor voltage and core frequency based on system usage. This can result in decreased average power consumption and decreased average heat production. Note: After enabling EIST in BIOS Setup, you need to enable it on your operating system as well. Consult your OS documentation for related instructions.	Enabled Disabled
Turbo Mode	Select whether to enable the Intel Turbo Boost technology. When enabled, the processor can maximize its core frequency while ensuring that it does not exceed its electrical and thermal specifications. Note: The number of active processor cores dictates the upper limit of Intel Turbo Boost technology.	Enabled Disabled
CPU C1E	Select whether to enable Enhanced Halt State. When enabled, a halt state is invoked during the OS idle period. This turns down the processor clock frequency (via multiplier control) resulting in lower power consumption.	Enabled Disabled
OS ACPI C3 Report	Select the preferred state for the processor core in C3 state (_CST as an ACPI C2/C3 state).	Enabled Disabled
CPU C6 Report	Select the preferred state for the processor core in C6 state (_CST as an ACPI C3 state).	Enabled Disabled

I/O Device Configuration submenu

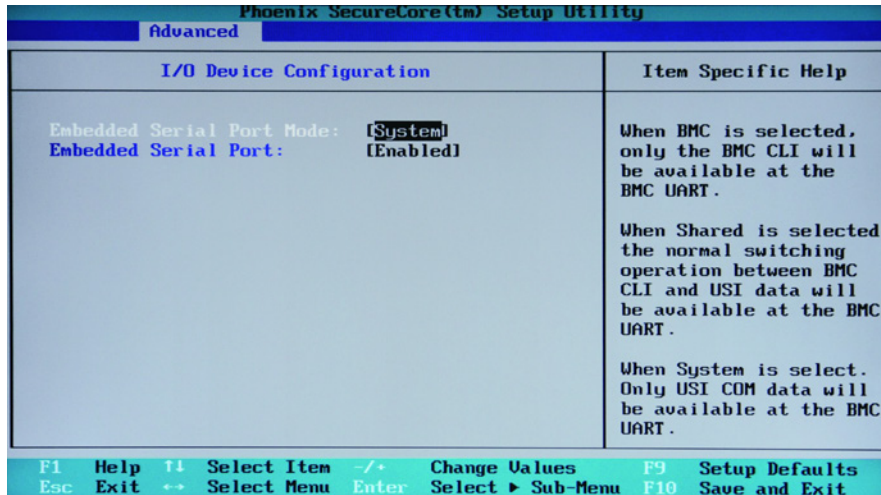

Field	Description	Options
Embedded Serial Port Mode	<p>Select the serial port operation mode.</p> <ul style="list-style-type: none"> • BMC – Only the BMC command line interface (CLI) is available at the BMC UART. • Shared – The switching operation between the BMC CLI and USI is available at the BMC UART. • System – Only the universal serial interface (USI) COM data is available at the BMC UART. <p>Note: BMC refers to the remote management processor.</p>	<p>BMC</p> <p>Shared</p> <p>System</p>
Embedded Serial Port	<p>This field allows the user to assign control for the serial port. When set to Enabled, users can manually configure the serial port settings</p>	<p>Enabled</p> <p>Disabled</p>

Hard Disk Configuration submenu

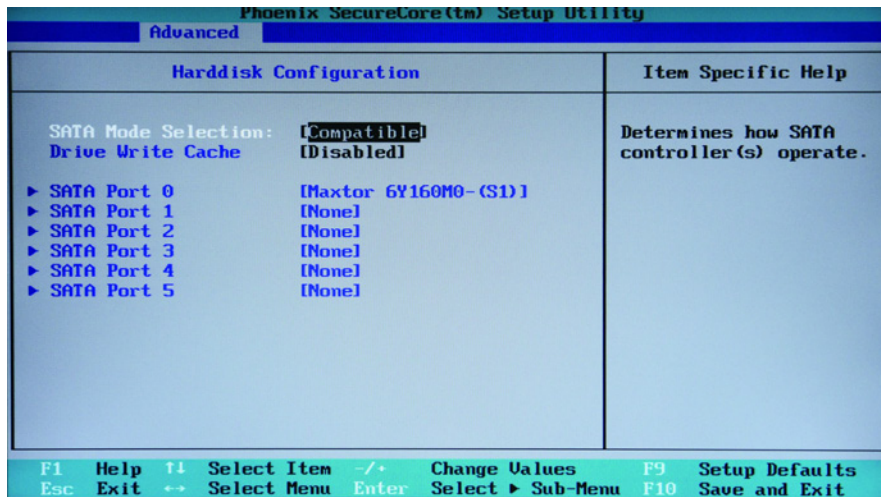

Field	Description	Options
SATA Mode Selection	<p>Select whether to enable the Advanced Host Controller Interface (AHCI) function of the SATA controller.</p> <ul style="list-style-type: none"> Enhanced – The SATA controller enables AHCI. The RAID function (if available) will also be enabled. The RAID setup utility will be accessible during boot-up. Compatible – The SATA controller disables both AHCI and RAID functions and runs in the IDE emulation mode. <p>Note: For operating systems that do not have native AHCI support, install the proper device driver first before enabling AHCI.</p>	Compatible Enhanced
Drive Write Cache	<p>Select whether to enable write caching for the installed hard drive(s). When enabled, the disk system can acknowledge a write operation as soon as the data is in the cache, not waiting for the data to be physically written.</p> <p>Caution: Write caching improves disk performance, but a power outage or equipment failure might result in data loss or corruption.</p>	Enabled Disabled
SATA Port 0–5	Press Enter to display the individual configuration screen of installed SATA drive(s).	

SATA Port 0–5 submenus

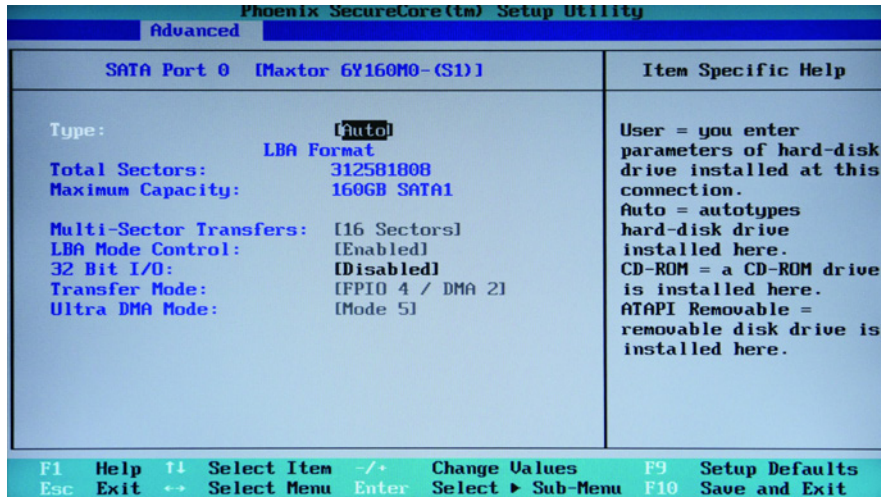

Field	Description	Options
Type	<p>Select the type of drive connected to the related port.</p> <ul style="list-style-type: none"> Auto – BIOS detects what the drive is capable of, not the translation mechanism that was used to format the drive. <p>Note: In this mode, if a drive is run in a mode other than the mode in which it was partitioned and formatted, unpredictable results may occur, including data loss.</p> <ul style="list-style-type: none"> CD-ROM – An optical disc drive is installed in this port. ATAPI Removable – An ATAPI removable drive is installed in this port. User – The user can manually edit other user-configurable fields in this submenu. This should be done only for hard drives that do not support the LBA mode, or are not automatically detected. <p>Note: The setting selected in this field will determine the availability of other fields/options in this submenu.</p>	<p>User</p> <p>Auto</p> <p>CD-ROM</p> <p>ATAPI Removable</p>
Cylinder	These fields should be edited only for hard drives that do not support the LBA mode, or are not automatically detected.	
Heads	Note: These fields are only available when the Type field is set to User .	
Sectors		
Total Sectors	Displays the total number of sectors in the hard drive, as well as its maximum capacity (LBA mode).	
Maximum Capacity	<p>Notes:</p> <ul style="list-style-type: none"> These two fields do not appear when the Type field is set to CD-ROM or ATAPI Removable. When the Type field is set to User, the value for the drive maximum capacity is determined in CHS (Cylinders, Heads, Sectors) mode. 	
Multi-Sector Transfer	<p>Select the number of sectors per block that the SATA controller is allowed to transfer per interrupt.</p> <p>Note: When the Type field is set to Auto this field is automatically detected and is not user-configurable.</p>	<p>Disabled</p> <p>2 Sectors</p> <p>4 Sectors</p> <p>8 Sectors</p> <p>16 Sectors</p>

Field	Description	Options
LBA Mode Control	Select whether to use the logical block addressing (LBA) scheme instead of the CHS scheme in specifying the location of data blocks. Note: When the Type field is set to Auto this field is automatically detected and is not user-configurable.	Enabled Disabled
32 Bit I/O	Select whether to enable 32-bit IDE data transfers. When enabled the IDE controller can combine two 16-bit hard disk reads into a single 32-bit data transfer to the processor. This boosts the performance of the IDE controller and the PCI bus.	Enabled Disabled
Transfer Mode	Select the method for moving data to and from the drive. Note: When the Type field is set to Auto this field is automatically detected and is not user-configurable.	Standard Fast PIO 1 Fast PIO 2 Fast PIO 3 Fast PIO 4 FPIO 3 / DMA 1 FPIO 4 / DMA 2
Ultra DMA Mode	Select the Ultra DMA (UDMA) mode for moving data to and from the drive. UDMA speeds up system bootup and access to drive data. Note: When the Type field is set to Auto this field is automatically detected and is not user-configurable.	Disabled Mode 0 Mode 1 Mode 2 Mode 3 Mode 4 Mode 5

USB Configuration submenu

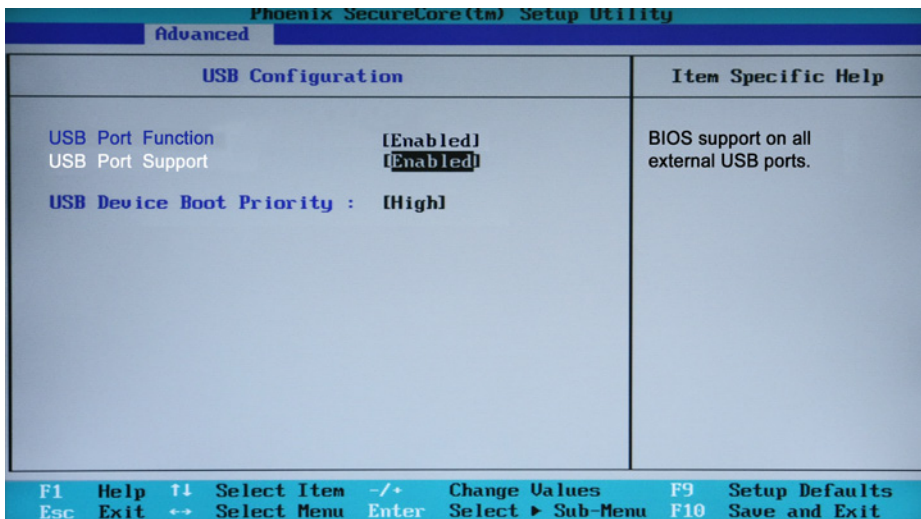

Field	Description	Options
USB Port Function	Select whether to allow the onboard USB controller to communicate with USB devices. Enable this field if you want to use the USB ports.	Enabled Disabled

Field	Description	Options
USB BIOS Support	Select whether to allow USB keyboard usage when accessing the BIOS Setup.	Enabled Disabled
USB Device Boot Priority	Set this field to High to enable the server to look for bootable USB devices first before any other device in booting the system. A USB key drive will be the first priority device.	High Low

IPMI submenu

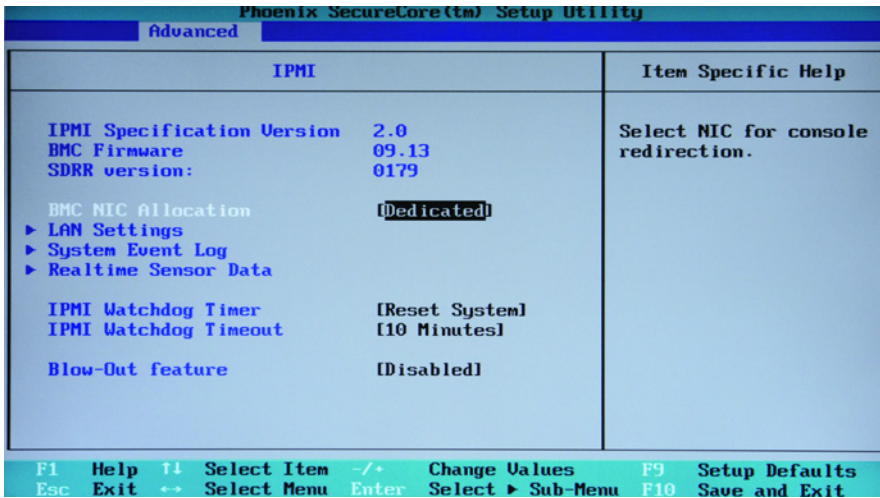

Field	Description	Options
IPMI Specification Version	IPMI standard compliance	
BMC Firmware	BMC firmware version	
SDRR Version	System data repository (SDR) version. SDR is stored in the BMC NVRAM and contains sensor and FRU data about all devices installed in the system.	
BMC NIC Allocation	Select which NIC port to use for console redirection. <ul style="list-style-type: none"> Dedicated – Select this option to run the IPMI remote functions through its own network line. Shared – Select this option to run the IPMI remote functions through the onboard NIC line. 	Dedicated Shared
LAN Settings	Displays LAN-related settings. Press Enter to access the related submenu.	
System Event Log	Displays system event log (SEL)-related settings. Press Enter to access the related submenu.	
Real Time Sensor Data	Press Enter to view a real time record of system temperature and voltages.	
IPMI Watchdog Timer	Select what system event to trigger when the IPMI watchdog timer is fired. The IPMI watchdog timer is a hardware timer built into the BMC that can trigger the system to automatically recover from a hang-up or faulty condition.	Disabled Reset System Power Down Power Cycle

Field	Description	Options
IPMI Watchdog Time-out	Select a countdown value for the IPMI watchdog timer. When the countdown reaches zero, the system event selected in the IPMI Watchdog Timer field is initiated.	5, 10, 15, 20, or 30 minutes
Blowout Feature	Select whether to enable the blowout feature. When enabled, the system ROM will initiate a blowout condition during POST where all fans will run at their high speed duration.	Enabled Disabled

LAN Settings submenu

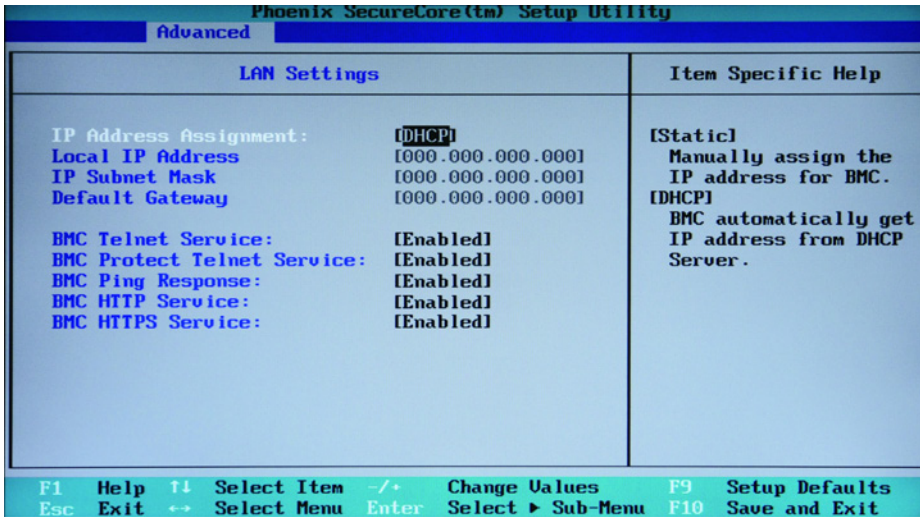

Field	Description	Options
IP Address Assignment	Select the method of assigning the BMC IP address. <ul style="list-style-type: none"> Static – Select this option to manually assign the BMC IP address. DHCP – Select this option to allow a DHCP server to assign the BMC IP address. 	Static DHCP
Local IP Address	The IP address, subnet mask, and default gateway address of the local system.	
IP Subnet Mask	When the IP Address Assignment field is set to DHCP, these fields are automatically assigned by the DHCP server.	
Default Gateway	When static IP addressing is used, manually key in the values for these fields.	
BMC Telnet Service	Select whether to enable the BMC Telnet service.	Enabled Disabled
BMC Protected Telnet Service	Select whether to enable the BMC SSH SSL service.	Enabled Disabled
BMC HTTP Service	Select whether to enable the BMC HTTP service.	Enabled Disabled
BMC HTTPS Service	Select whether to enable the BMC HTTPS service.	Enabled Disabled

System Event Log submenu

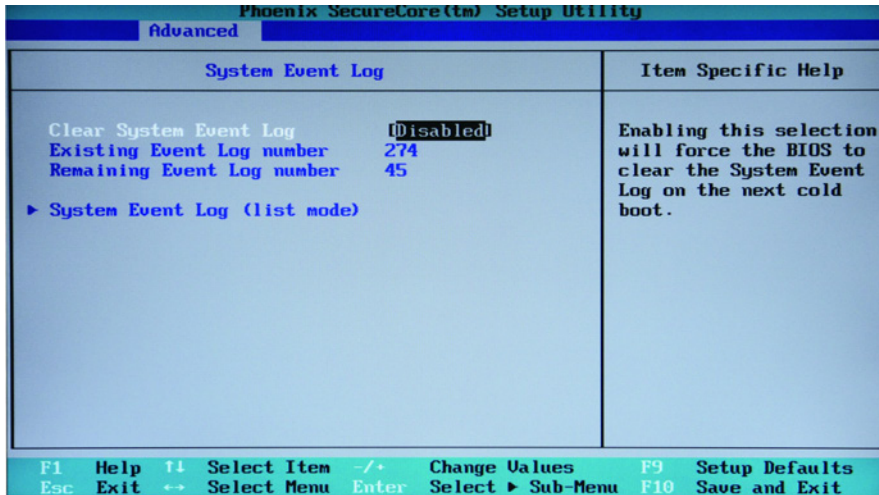

Field	Description	Options
Clear System Event Log	Select whether to delete all system event log (SEL) entries during the next system start-up.	Enabled Disabled
Existing Event Log Number	Number of recorded SEL entries	
Remaining Event Log Number	Number of remaining SEL entries	
System Event Log (list mode)	Press Enter to view the SEL in list mode. To view the details of a SEL entry, select it then press Enter .	

System event log screen

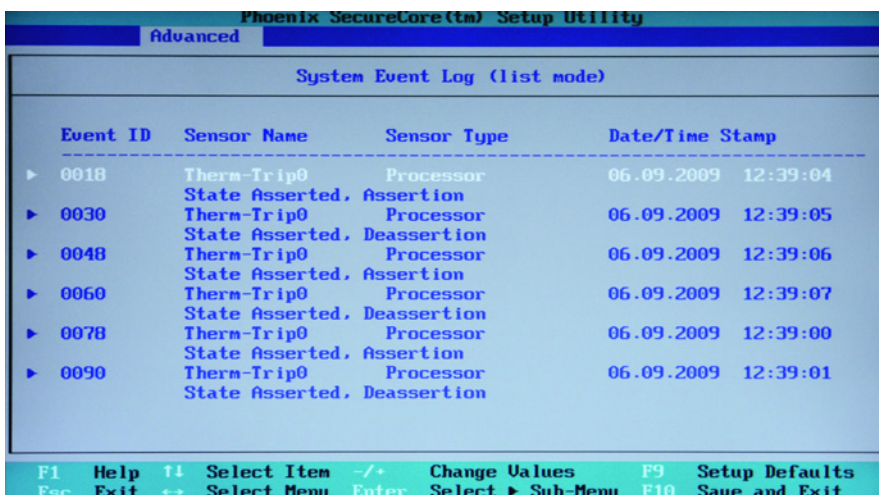

The SEL data is stored in BMC NVRAM. It contains logs of all:

- sensor threshold violations
- monitored device errors
- IPMI watchdog timer events
- power ON/OFF requests

Each SEL entry indicates the:

- Event ID (number assigned to identify the event type)
- Device sensor that was activated
- Device that caused the event
- Date and time of event occurrence
- Event description

Real Time Sensor Data screen

The **Real Time Sensor Data** screen displays the current thermal and voltage values for various hardware monitors. The minimum and maximum threshold levels are also indicated. Use the **PgUp** and **PgDn** keys to view the entire record.

Sensor Type	Sensor Name	Sensor Data	Sensor Units	Lower Limit	Upper Limit
Temperature					
	SYS Ambient Temp	0.00	degrees C	0.00	42.00
	CPU0 Dmn0 Temp	42.00	degrees C	0.00	100.00
	CPU0 Dmn1 Temp	N/A	degrees C	0.00	95.00
	DDR Ambient Temp	32.00	degrees C	0.00	72.50
	PCI Ambient Temp	21.00	degrees C	0.00	66.00
	DIMMA1 Temp	30.00	degrees C	0.00	87.00
	DIMMA2 Temp	30.00	degrees C	0.00	87.00
	DIMMB1 Temp	27.50	degrees C	0.00	87.00
	DIMMB2 Temp	30.00	degrees C	0.00	87.00

F1 Help ↑ Select Item -/+ Change Values F9 Setup Defaults
 Esc Exit → Select Menu Enter Select ▶ Sub-Menu F10 Save and Exit

Console Redirection submenu

Console Redirection		Item Specific Help
BIOS Serial Console Port:	Disabled	Enable/Disable Console Redirection.
Baud Rate	19600	

F1 Help ↑ Select Item -/+ Change Values F9 Setup Defaults
 Esc Exit → Select Menu Enter Select ▶ Sub-Menu F10 Save and Exit

Field	Description	Options
BIOS Serial Console Port	Select whether to enable the serial port for console redirection. When enabled, users can access the system BIOS and monitor the server from a remote location using a serial port connection.	Enabled Disabled

Field	Description	Options
Baud Rate	Select the baud rate for console redirection.	9600 19.2K 38.4K 57.6K 115.2K

Security menu

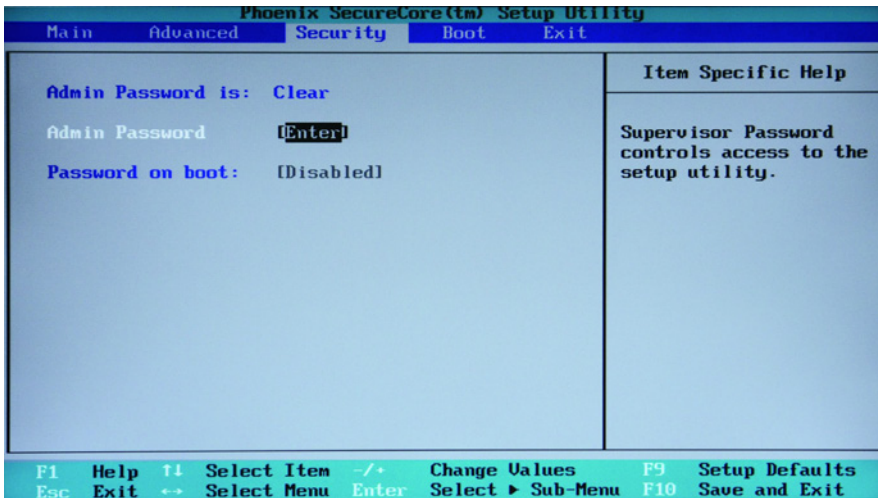

Field	Description
Admin Password Is	Current admin password status (Clear or Set)
Admin Password	Select the field, and then press Enter to set, change, or remove the admin password. The admin password allows the user to access and change all settings in the Setup Utility.
Password on Boot	Select whether to require the admin password during bootup.

To set an admin password:

1. In the **Security** menu screen, select the **Admin Password** field then press **Enter**.

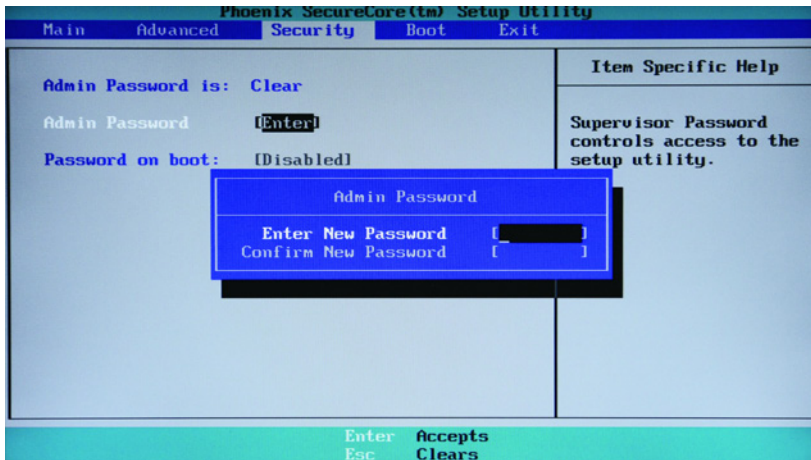

2. Type a new password in the password box.
The password may consist of up to eight alphanumeric characters (A-Z, a-z, 0-9).
3. Retype the password to verify the first entry, and then press **Enter**.
4. Press **F10** to save the password and close the Setup Utility.

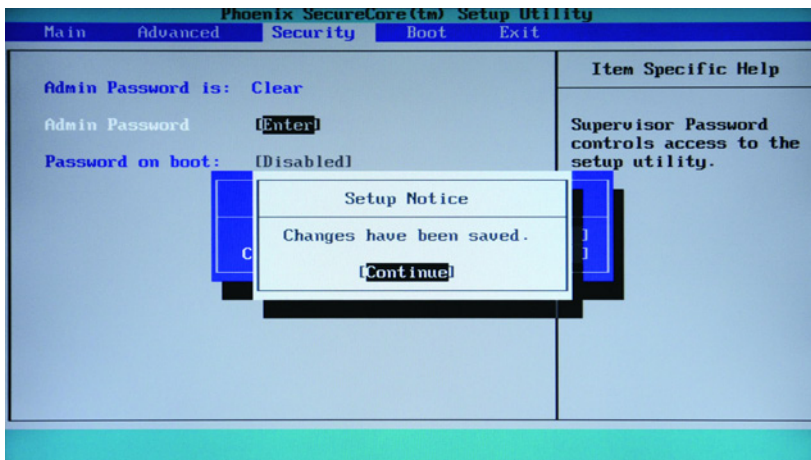

After setting the password, the **Admin Password Is** field value changes to **Set**.

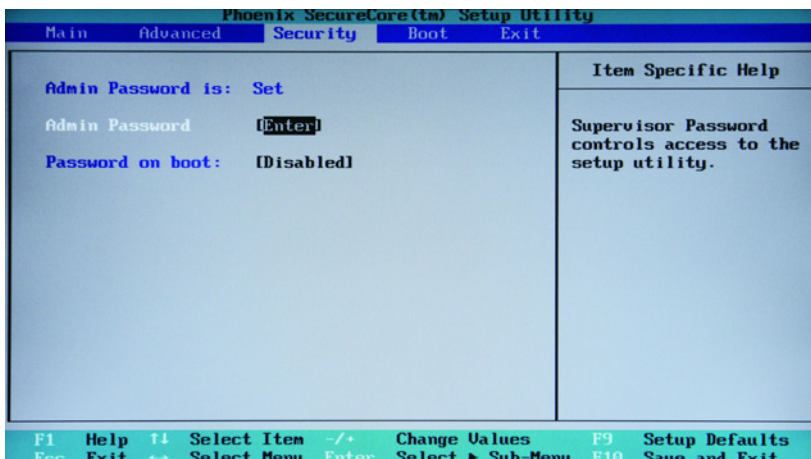

To change the admin password:

1. In the **Security** menu screen, select the **Admin Password** field, and then press **Enter**.
2. Type the original password in the password box.
3. Type a new password, and then press **Enter**.
4. Retype the new password to verify the first entry, and then press **Enter** again.
5. Press **F10** to save the password and close the Setup Utility.

To remove the admin password:

1. In the **Security** menu screen, select the **Admin Password** field, and then press **Enter**.
2. Type the original password then press **Enter**.
3. Press **Enter** twice without entering anything in the new and confirm password fields.
4. Press **F10** to save the changes you made and close the Setup Utility.
The **Admin Password Is** field value is set to **Clear**.

To reset the admin password:

If you forget the admin password, use switch 8 of the system configuration switch (PCHSW1) to reset it. See [page 107](#) for the location of this switch.

1. Perform the pre-installation procedure.
2. Locate the PCHSW1 switch on the system board.
If necessary, remove any assemblies or cables that prevent access to the PCHSW1 switch.
3. Flip switch 8 to the **On** position for about 3 seconds.
4. Flip switch 8 back to the default **Off** position.
5. Perform the post-installation procedure.
6. During POST, press **F10** to access the Setup Utility.
7. Press **F9** to load the system default values.
8. Press **F10** to save the changes you made and close the Setup Utility.

Boot menu

Use this menu to set the preferred drive sequence in which the Setup Utility attempts to boot the operating system.

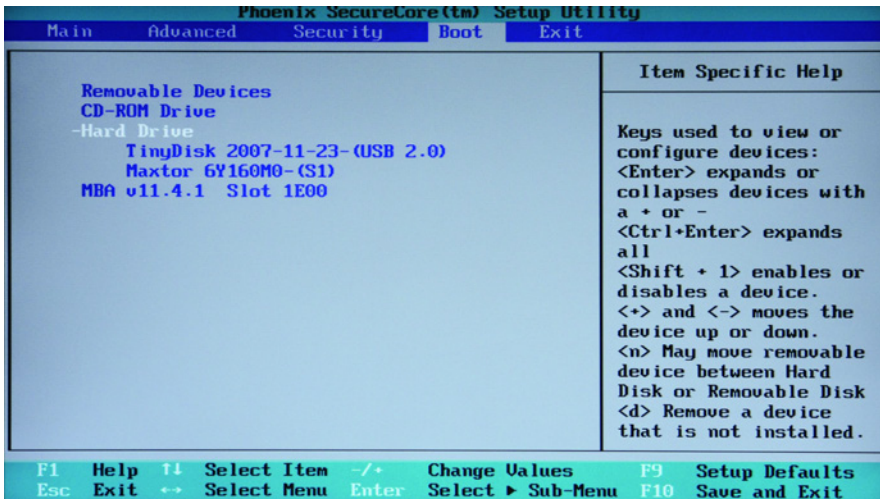

By default, the server searches for boot devices in the following order:

- Removable devices
- CD-ROM/DVD-ROM drive
- Hard drive
- MBA v11.4.1 Slot 1E00 – This option enables PXE implementation (Preboot Execution Environment—remote boot over LAN) using the embedded NIC port.

To implement the PXE boot option, you need to first set the **Embedded NIC Port 1 PXE** field under the **Main | Boot Features** submenu of the Setup Utility to **Enabled**.

Exit menu

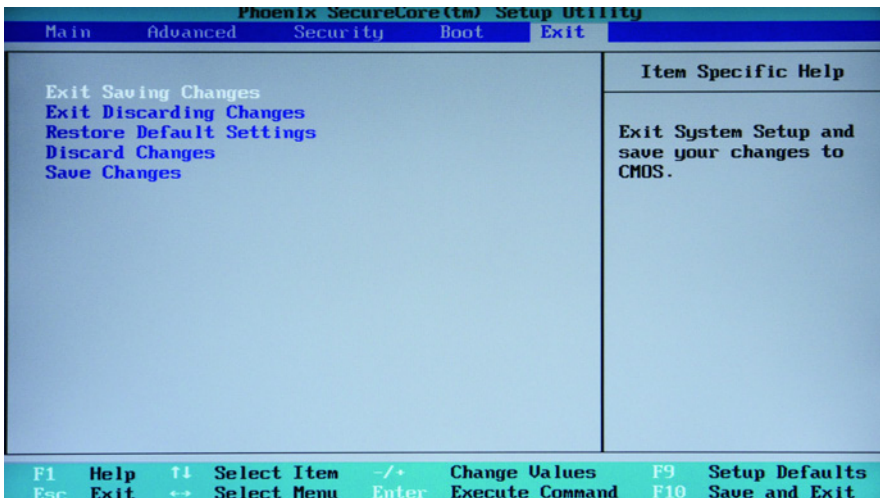

Field	Description
Exit Saving Changes	Saves changes made and closes the Setup Utility. Keyboard shortcut: F10

Field	Description
Exit Discarding Changes	Discards changes made and closes the Setup Utility.
Restore Default Settings	Loads the factory-default settings for all Setup parameters. Keyboard shortcut: F9
Discard Changes	Discards all changes made to the Setup Utility and loads the previous configuration settings.
Save Changes	Saves all changes made to the Setup Utility.

BIOS splash screen

The BIOS splash screen displays basic and important information about the current server configuration and is necessary for troubleshooting and may be required when asking for technical support. It is recommended that you check this screen during the initial system setup and each time you install, remove, or upgrade accessories.

To view the BIOS splash screen:

You first need to enable the display of the splash screen during bootup. Follow the steps below.

1. In the **Main** menu screen, select the **Boot Features** field, and then press **Enter**.
2. Select the **Splash Screen** field.
3. Press the plus (+) or minus (-) key to set the field to **Enabled**.
4. Press **F10** to save the changes you made and close the Setup Utility.
5. Reboot the server.

The splash screen is displayed briefly at the end of POST.

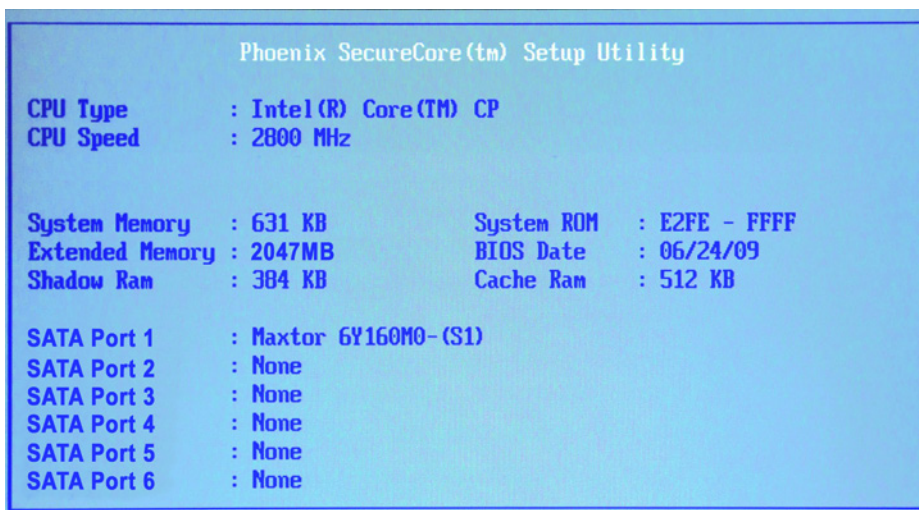

6. Press the **Pause/Break** key to continue displaying the screen until another key is pressed.
7. Press any key to continue with the system bootup.

Recording custom Setup values

Keep a record of the custom Setup values you have set up for your system BIOS. If the custom values ever need restoring (after a CMOS clear, for example), you must run the Setup Utility and enter these custom settings again. Make sure to update this record whenever you make any change to these Setup settings or install new hardware.

You can either record the Setup values manually (hard copy) or use a CMOS backup utility.

To manually record the custom Setup values:

1. Access the Setup utility.
2. Go through each menu and submenus page, and press **Print Screen** to make a hard copy.
3. For multiple page menus, move to each page and print each screen.

If a printer is not available, write down the values on a piece of paper. Make sure to write them down legibly and accurately.

4. Label and date the Setup values hard copy, and then store it in a safe and accessible place, preferably with other user documentation for your ProLiant server.

CMOS backup utility

There are third-party utilities that read the CMOS settings and record them to a regular file, which can then be backed up through normal means, or copied to an external storage media. Some of these utilities also offer the option of restoring the CMOS settings so you need not re-enter them manually.

These utilities are not always compatible with all versions of CMOS or types of CMOS. In addition, these utilities are not compatible with all operating system versions. Be sure to use a CMOS backup utility that is designed for the particular CMOS type and OS version installed in your ProLiant server. For information on a compatible CMOS backup utility, contact your local HP representative.

Loading system defaults

If your system fails after you make changes in the Setup menus, reboot the server, enter Setup and load the system default settings to correct the error.

To load the system defaults:

1. Reboot the server in a normal manner.
2. During POST, press **F10** to access the Setup Utility.
3. Press **F9** to load the default values.
4. Press **F10** to save the changes you made and close the Setup Utility.

Clearing CMOS

You may need to clear the Setup configuration values (CMOS) if the configuration has been corrupted, or if incorrect settings made in the Setup Utility caused error messages to be unreadable.

Use switch 1 of the system configuration switch (PCHSW1) to clear the CMOS data. See [page 107](#) for the location of this switch.

To clear CMOS:

1. Perform the pre-installation procedure.
2. Locate the PCHSW1 switch on the system board.
3. If necessary, remove any assemblies or cables that prevent access to the PCHSW1 switch.
4. Flip switch 1 to the On position for about 3 seconds.
5. Flip switch 1 back to the default Off position.
6. Perform the post-installation procedure.
7. During POST, press **F10** to access the Setup Utility.
8. Press **F9** to load the system default values.
9. Press **F10** to save the changes you made and close the Setup Utility.

Recovering BIOS

An interruption during a BIOS update procedure (for example, a power outage) can corrupt the BIOS code, which will cause the system to go into an unbootable state. You need to access and execute the boot block code to reboot the server and recover the regular BIOS code.

Use switch 2 of the system configuration switch (PCHSW1) to execute the boot block code. See [page 107](#) for the location of this switch.

To execute the BIOS boot block code:

1. Go to www.hp.com and download the following files to the root directory of a bootable device. You can use a diskette, an external USB drive, or a CD/DVD.
 - a. ROMPAQ.exe
 - b. CPQSRVR2.cpu
 - c. CPQO270x.xxx
 - d. CONFIG.sys
2. Create and label a bootable ROMPAQ device using the downloaded files.
3. Change the command line in CONFIG.sys with:

```
shell = rompaq.exe /! /U CPQSRVR2.CPU CPQO260x.xxx
```
4. Perform the pre-installation procedure.

5. Locate the PCHSW1 switch on the system board.
6. If necessary, remove any expansion boards, assemblies or cables that prevent access to the PCHSW1 switch.
7. Flip switch 2 to the On position, then flip it back to the default Off position.
8. Perform the post-installation procedure.
9. Reboot the server using the bootable ROMPAQ device you created in step 2.
The system will initiate BIOS auto recovery. This process may take 20–30 minutes.

Flashing the system BIOS

Flash the system BIOS to ensure server support for new hardware releases. In cases of a damaged or corrupted BIOS code, you need to execute the BIOS boot block code, then flash the BIOS to make sure it has the latest BIOS image.

Refer to the previous section for instructions on how to execute the boot block code.

To flash the system BIOS:

1. Go to www.hp.com and download the following files to the root directory of a bootable device. You can use a diskette, an external USB drive, or a CD/DVD.
 - a. ROMPAQ.exe
 - b. CPQSRVR2.cpu
 - c. CPQO270x.xxx
 - d. CONFIG.sys
2. Create and label a bootable ROMPAQ device using the downloaded files.
3. Reboot the server using the bootable ROMPAQ device.
4. Follow the onscreen instructions to update the system BIOS.

Power-On-Self-Test

Before you can use a server, all devices must be tested and initialized, and the operating system must be bootstrapped to the memory. This is referred to as Power-On-Self-Test or POST. POST is a series of diagnostic tests that checks firmware and hardware components to ensure that the server is properly functioning. This diagnostic function automatically runs each time the server is powered on.

These diagnostics, which reside in the BIOS ROM, isolate server-related logic failures and indicate the board or component that needs to be replaced, as indicated by the error messages. Most server hardware failures will be accurately isolated during POST. The number of tests displayed depends on the configuration of the server.

POST error indicators

When POST detects a system failure, it either displays a POST error message, or emits a series of beep codes.

POST errors messages

Whenever a non-critical error occurs during POST, an error message describing the problem appears onscreen. These text messages are displayed in normal video (white text on black background). It shows the details of the error. The following is an example of a POST error message:

```
ERROR
```

```
0251: System CMOS checksum bad - Default configuration used
```

In some cases an error message may include recommendations for troubleshooting or require that you press the **Enter** key to display recommendations. Follow the instructions on the screen.

The next table lists the most common POST error messages with their corresponding troubleshooting recommendation. It is recommended that you correct the error before proceeding, even if the server appears to boot successfully.

If your system displays one of the messages marked below with an asterisk (*), write down the code and message and contact your HP Customer Support provider.

When no POST error message is displayed but the server stops during POST, listen for beep codes.

Error code	Error message	Corrective action/description
0200	Failure Fixed Disk	Fixed disk is not working or not configured properly. 1 Run Setup and check if the fixed-disk type is correctly identified. 2 Check to see if the fixed disk is attached properly.
0210	Stuck key	Stuck key on keyboard. 1 Locate the stuck key on your keyboard and release it. 2 Reboot the server.
0211	Keyboard error	Keyboard not working. Verify that the keyboard cable is securely connected to the keyboard port (not the mouse port) on the rear panel of the server. If the problem persists, replace the keyboard or contact your HP Customer Support provider.
0212	Keyboard Controller Failed	Keyboard controller failed test.

Error code	Error message	Corrective action/description
0213	Keyboard locked - Unlock key switch	Keyboard error. Replace the keyboard.
0220	Monitor type does not match CMOS - Run SETUP	The attached monitor cannot be correctly identified by Setup. Run Setup and check if the monitor type is correctly identified.
0230	System RAM failed at offset	One or more defective memory module. <ol style="list-style-type: none"> 1 Remove all installed DIMMs. 2 Reinstall the DIMMs one by one to identify the defective module. 3 Replace the DIMM with a new one.
0231	Shadow RAM failed at offset	
0232	Extended RAM Failed at offset: nnnn	
0250	System battery is dead - Replace and run SETUP	The CMOS clock battery indicator shows the system battery is dead. <ol style="list-style-type: none"> 1 Replace the system battery following the procedures on page 66. 2 Run Setup to reconfigure the system.
0251	System CMOS checksum bad - Default configuration used	The settings in the Setup Utility have been corrupted or modified incorrectly, perhaps by an application program that changes data stored in CMOS. Access Setup, and then either load the system default values or enter your own custom values. If the error persists, check the system battery or contact your HP Customer Support provider.
0260	System timer error	The timer test failed. Requires repair of the system board.
0270	Real time clock error	Real-Time Clock (RTC) fails BIOS hardware test. May require board repair.
0271	Check date and time settings	BIOS found date or time is out of range. May require setting legal date (1991-2099). Access Setup and check the values in the System Time and System Date fields of the Main menu.
0280	Previous boot incomplete - Default configuration used	Initial bootup failed. BIOS automatically loads the default system values and then boots again.
0281	Memory size found by POST differed from CMOS	The user added or removed a memory module, thus the system memory size is different from the previous bootup value.
02D0	System cache error - Cache disabled	Processor error. Replace the processor.
02F0	CPU ID:	–
02F4	EISA CMOS not writeable	System board failure. Replace the system board.
02F5	DMA Test Failed	The DMA control test failed.
02F6	Software NMI Failed	An NMI signal is detected.

POST related troubleshooting

Perform the following procedures when POST fails to run, displays error messages, or emits beep codes.

If the POST failure is during a routine boot up, check the following:



- All external cables and power cables should be firmly plugged in.
- The power outlet to which the server is connected and is working.
- The server and monitor are both turned on. The bicolor status LED indicator on the front panel must be lit up green.
- The monitor's contrast and brightness settings are correct.
- All internal cables are properly connected and all boards are firmly seated.
- The processor is fully seated in its socket on the system board.
- The heat sink is properly installed on top of the processor.
- All memory modules are properly installed.
- If you have installed a PCI expansion board, verify that the board is firmly seated and any switches or jumpers on the board are properly set. Refer to the documentation provided with the expansion board.
- All system cables are securely connected and are in their proper order.
- If you have changed any switches on the system board, verify that each is properly set.

Connectors, switches, and LEDs

Connectors and components

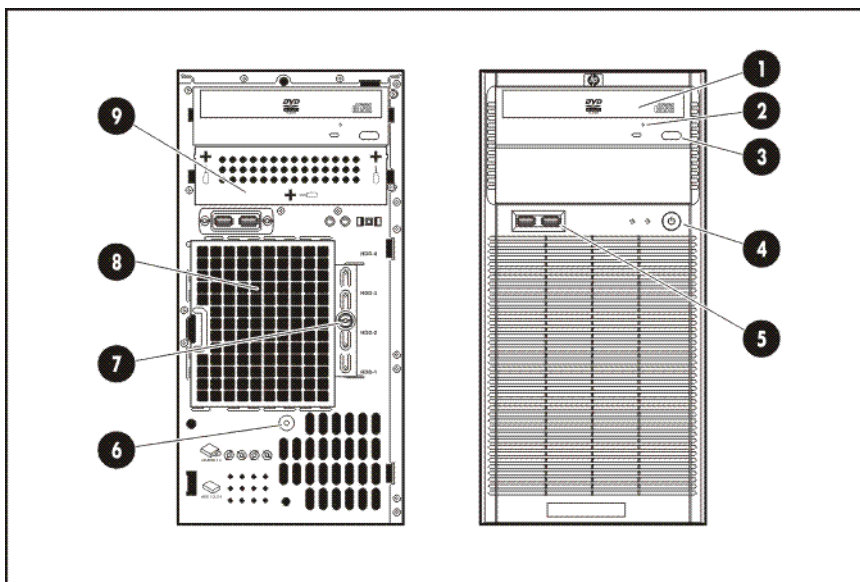
Front panel







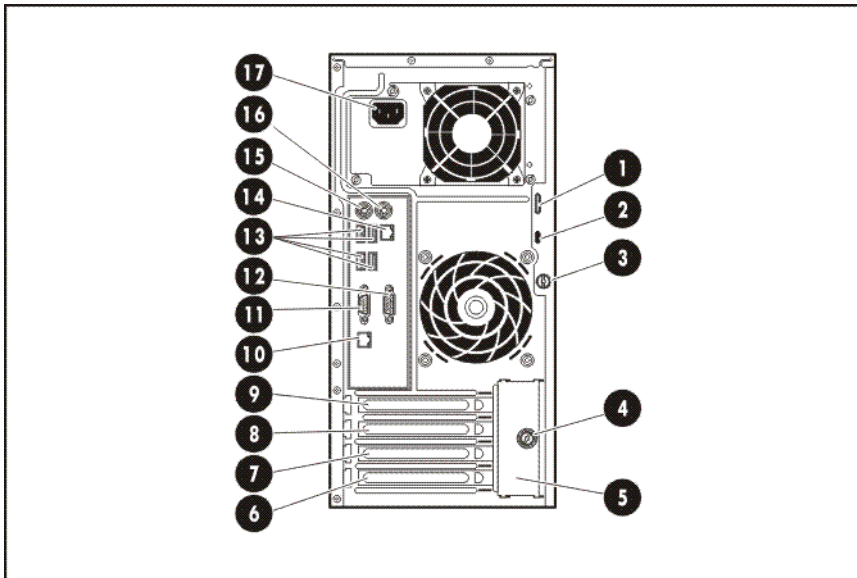

Item	Icon	Component
1		Optical disc drive (ODD)
2		ODD manual eject hole
3		ODD eject button
4		Power button
5		Front USB 2.0 ports
6		External ambient thermal sensor
7		HDD EMI shield thumbscrew
8		HDD EMI shield
9		Second removable media drive bay EMI shield

NOTE: The location of items 2 and 3 may vary depending on the model of the installed removable media drive.

Rear panel



Item	Icon	Component
1		Kensington lock notch
2		Cable lock provision notch
3		Access panel thumbscrew
4		Expansion slot cover retainer thumbscrew
5		Expansion slot cover retainer
6		Expansion slot 1 cover
7		Expansion slot 2 cover
8		Expansion slot 3 cover
9		Expansion slot 4 cover
10		Management NIC port (RJ-45)
11		Video port
12		Serial port
13		USB 2.0 ports
14		Embedded NIC port (RJ-45)
15		PS/2 keyboard port
16		PS/2 mouse port
17		Power supply cable socket

System board

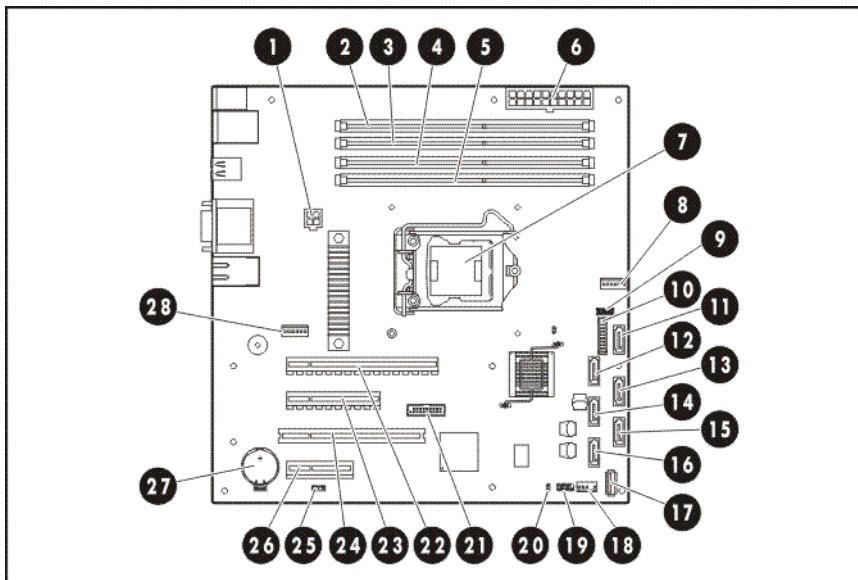

Item	Code	Component
1	ATXPWRCN2	4-pin ATX processor power connector
2	DIMM4B	Channel B 1 st DDR3 DIMM slot
3	DIMM3D	Channel B 2 nd DDR3 DIMM slot
4	DIMM2A	Channel A 1 st DDR3 DIMM slot
5	DIMM1C	Channel A 2 nd DDR3 DIMM slot
6	ATXPWRCN1	24-pin ATX system board power connector
7	CPU1	Processor
8	CPUFAN1	Heat sink cable connector
9	PCHSW1	System configuration switch
10	FPCN1	Power button / front panel LED cable connector
11	SATA1	1 st HDD SATA cable connector
12	SATA2	2 nd HDD SATA cable connector
13	SATA3	3 rd HDD SATA cable connector
14	SATA4	4 th HDD SATA cable connector
15	SATA5	1 st ODD SATA cable connector
16	SATA6	2 nd ODD SATA cable connector
17	USBCONN2	Internal USB connector for STD USB
18	USBCONN3	Internal USB connector for tape device
19	FPUSBCONN1	Front panel USB port connector
20	HDDLEDCN1	External HDD LED cable connector

Item	Code	Component
21	TPMCN1	TPM (Trusted Platform Module) connector
22	Full-height full-length Slot 4 PCIe x16 (16) 45W	Full-height/full-length PCIe Gen2 x16 slot (x16)
23	Full-height full-length Slot 3 PCIe x8 (4) 25W	Full-height/full-length PCIe Gen1 x8 slot (x4)
24	Full-height full-length Slot 2 PCI 32-bit 33 MHz 25W	Full-height/full-length 32-bit/33 MHz PCI slot
25	THERSNRCN1	Cable connector for the external ambient thermal sensor
26	Full-height half-length Slot 1 PCIe x4 (1) 25W	Full-height/half-length PCIe Gen1 x4 slot (x1)
27	BATSOCKET1	System battery
28	REARFAN1	System fan cable connector

NOTE: The TPM is a hardware-based system security feature that can securely store information, such as passwords and encryption keys, which can be used to authenticate the platform. To prevent possible damage to the TPM module or to the system board, the TPM cannot be removed from the board once it has been installed.

System configuration switch

PCHSW1 is an eight-position switch on the system board used to implement the various protections and override functions. All eight switches will have the off position as the default setting.

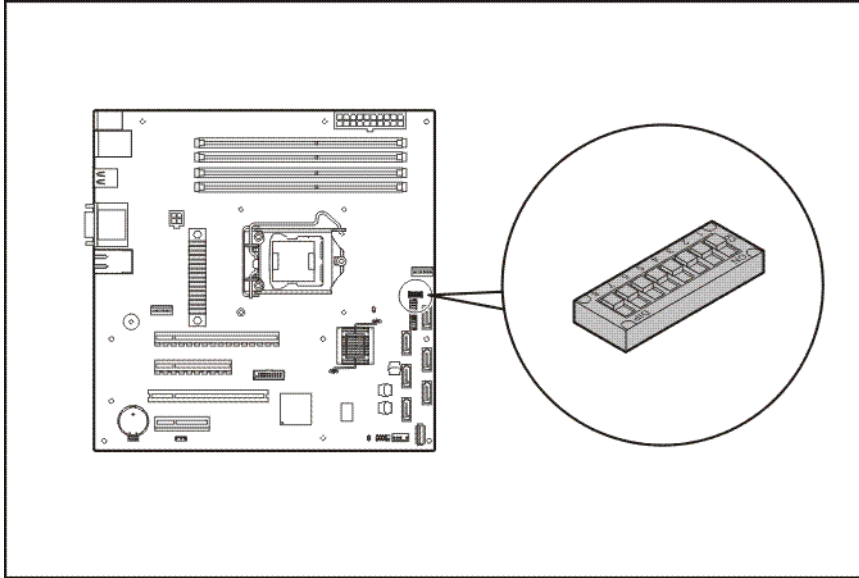

Position	Function	Default	Description
1	Configuration reset	Off	Off: Normal On: System configuration settings and registry are reset to default values.
2	BIOS recovery	Off	Off: Normal BIOS boot block On: Recovery BIOS boot block
3	RAID key (reserved)	Off	Off: Disable RAID key On: Enable RAID key
4	Reserved	Off	—
5–7	Reserved for chassis ID 0, 1, and 2	Off	—
8	Password clear	Off	Off: Normal On: Clears the BIOS admin password.

Status LED indicators

The status LED indicators aid in problem diagnosis by indicating the status of system components and operations of the server.

External LED indicators

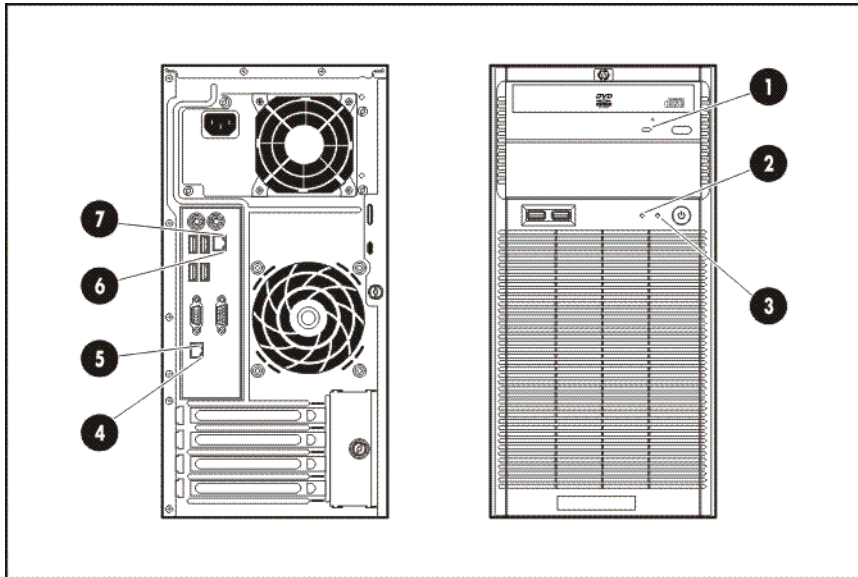

Item	Indicator	Status	Description
1	ODD activity	Green	Ongoing ODD activity
2	HDD activity	Green	Ongoing HDD activity
3	System power	Green	Power on mode
		Amber	Standby mode
4	Management NIC link	Green	Network link established
5	Management NIC activity	Blinking green	Ongoing network activity
6	Embedded NIC activity	Blinking green	Ongoing network activity
7	Embedded NIC link	Green	100 Mbps connection
		Orange	Gigabit connection

System board LED indicators

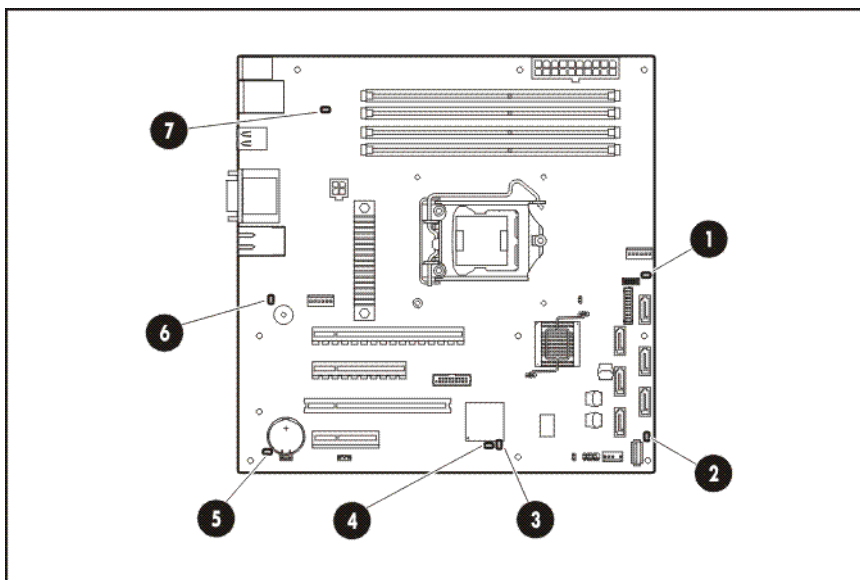

Item	Indicator	Status	Description
1	Heat sink failure	Amber	Heat sink error detected
2	DC power on	Green	System is turned on.
3	Management controller heartbeat	Blinking green	Baseboard Management Controller (BMC) activity
4	System/processor over temperature (OTP)	Amber	A system or processor temperature sensor has been breached.
5	Standby power	Green	System is in standby mode.
6	System fan failure	Amber	System fan error detected
7	Memory module failure	Amber	Memory module error detected

System specifications

Hardware specifications

System unit

Item	Description
Processor socket	Intel LGA 1156
Processor support	Intel Celeron G1101, Intel Pentium G6950, Intel Core i3-530, Intel Core i3-540, and Intel Xeon 3400 series processors
Core logic	Intel Platform Controller Hub (PCH)
Bridge interface	Intel DMI (Direct Media Interface), 2.5 GT/s
Hardware monitoring chipset	ServerEngines Pilot II Server Management Controller
Ethernet controller	Broadcom NetXtreme BCM5723
Memory controller	Integrated in the Intel processor
Storage controller	<ul style="list-style-type: none">• SATA – Integrated in the Intel PCH• SAS – SAS controller board (optional)
Graphics controller	Integrated in the ServerEngines Pilot II
I/O subsystem	<ul style="list-style-type: none">• Full-height/full-length PCIe Gen2 x16 slot (x16)• Full-height/full-length PCIe Gen1 x8 slot (x4)• Full-height/full-length 32-bit/33 MHz PCI slot• Full-height/half-length PCIe Gen1 x4 slot (x1)
Memory	<ul style="list-style-type: none">• Two memory channels of two DDR3 slots each• Supports PC3-10600E UDIMM with ECC support
Media storage	<ul style="list-style-type: none">• Two half-height media bays for optical media and storage/tape drives• Four 3.5-inch bays for non-hot-plug SAS or SATA drives
I/O ports	<ul style="list-style-type: none">• Front panel – Two USB ports• Rear panel – PS/2 keyboard port, PS/2 mouse port, four USB ports, embedded NIC port, video port, serial port, and remote management port• Internal – One USB port each for a STD USB (USBCONN2) and a tape device (USBCONN3)
Status LED indicators	<ul style="list-style-type: none">• Front panel – Optical drive activity, hard drive activity, and power• Rear panel – Activity and link status for the embedded/management NIC ports• System board – DC power on, standby, management controller heartbeat, heat sink failure, system fan failure, memory module failure, and over temperature

Item	Description
Server management	<ul style="list-style-type: none"> • Onboard hardware failure indicators • Management NIC <ul style="list-style-type: none"> ◦ IPMI 2.0 compliant ◦ Dedicated 10/100 Mbps LAN port for online system health monitoring
Thermal solution	<ul style="list-style-type: none"> • One system fan • One heat sink • One PSU fan

Memory

Item	Description
Number of DIMM slots	Four
Memory controller	Integrated in the Intel processor
Memory configuration mode	<ul style="list-style-type: none"> • Single channel mode (DIMM2A) • Dual channel mode (interleaving) (DIMM2A and DIMM4B)
DIMM specifications	
Size	1, 2, or 4 GB PC3-10600E UDIMM
Transfer rate	1333 MT/s
NOTE: Memory transfer rate depends on the current memory configuration mode and processor installed.	

Processor

Item	Description
Manufacturing technology	45 nm
Thermal design power	95 W
Socket type	LGA 1156
Supported processors	<ul style="list-style-type: none"> • Intel Xeon X3460 (8M cache, 2.80 GHz) • Intel Xeon X3450 (8M cache, 2.66 GHz) • Intel Xeon X3440 (8M cache, 2.53 GHz) • Intel Xeon X3430 (8M cache, 2.40 GHz) • Intel Celeron G1101 (2M cache, 2.26 GHz) • Intel Pentium G6950 (3M cache, 2.80 GHz) • Intel Core i3-530 (4M cache, 2.93 GHz) • Intel Core i3-540 (4M cache, 3.06 GHz)

Power supply unit

Item	Description
Model	DPS-300AB-50 A
Output power	300 W
Input requirements	
Input voltage range	90–264 VAC, single phase
Nominal input voltage	100–240 VAC
Line frequency	47–63 Hz
Maximum input current	5 A at 100 VAC; 2.5 A at 200 VAC
Dimensions	
Height	86 mm (3.39 in)
Depth	140 mm (5.51 in)
Width	150 mm (5.91 in)
Weight (approximate)	1.44 kg (3.17 lb)
Operating conditions	
Temperature	10–45 °C (50–113 °F)
Relative humidity (non-condensing)	8–90%

Software specifications

Item	Description
Network operating system (NOS) support	<ul style="list-style-type: none">• Microsoft Windows Server 2003 R2• Microsoft Windows Server 2003 R2 Enterprise Edition• Microsoft Windows Server 2003 R2 Web Edition• Microsoft Windows Server 2003 R2 Embedded Edition• Microsoft Windows Server 2008• Microsoft Windows Server 2008 Enterprise Edition• Microsoft Windows Server 2008 Web Edition• Microsoft Windows Server 2008 Embedded Edition• Microsoft Windows Small Business Server 2008• Microsoft Windows Essential Business Server 2008• Windows Web Server 2008 R2• Microsoft Windows Server 2008 R2 Datacenter• Windows Server 2008 R2 Foundation• Red Hat Enterprise Linux 4• Red Hat Enterprise Linux 5• Red Hat Enterprise Linux 6• SUSE Linux Enterprise Server 10• SUSE Linux Enterprise Server 11
System diagnostics	<ul style="list-style-type: none">• HP Insight Diagnostics• Survey Utility• Array Diagnostic Utility• HP Instant Support Enterprise Edition• Web-Based Enterprise Service• Open Services Event Manager• Phoenix SecureCore Setup Utility

Physical specifications

Item	Description
System board platform	uATX (Micro Advanced Technology Extended)
System board dimensions	
Length	244 mm (9.6 in)
Width	244 mm (9.6 in)
Server dimensions (not including the front bezel and foot stand)	
Height	365.22 mm (14.38 in)
Width	175 mm (6.9 in)
Depth	With bezel – 423 mm (16.65 in) Without bezel – 390 mm (15.35 in)
Server weight (maximum configuration, approximate)	
Basic configuration	11.40 kg (25.13 lb)
Fully loaded configuration	13.85 kg (30.53 lb)

Environmental specifications

Item	Description
Temperature range	
Operating	0–35 °C (32–95 °F)
Non-operating	-35–65 °C (-31–149 °F)
Humidity (non-condensing)	
Operating	10–90% RH
Non-operating	10–95% RH
Altitude	
Operating	0–10,000 ft
Non-operating	0–30,000 ft
Acoustic noise	
Idle, minimum (fixed disk drives spinning)	L Wad – 4.32 BELS L pAm – 24.9 dBA
Operating, minimum (random seeks to fixed disk drives)	L Wad – 4.41 BELS L pAm – 25 dBA
NOTE: The listed sound levels apply to standard shipping configurations. Additional options may result in increased sound levels.	

Index

A

- AC power
 - power-down procedure, 30
 - system board LED indicator, 105
- access panel
 - part number, 17
 - removing, 32
- admin password
 - changing, 90
 - removing, 90
 - resetting, 90
 - setting, 89

B

- Basic Input/Output System, 70
- battery
 - location, 61
 - replacement warnings, 61
 - replacing, 62
- BIOS. *See* Basic Input/Output System
 - CMOS clear, 94
 - flashing, 95
 - recovering, 94
 - updating, 95
- BIOS boot block, 94
- BIOS splash screen
 - viewing, 92

BMC

- system board LED indicator, 105

boot sequence

- default settings, 91

C

- cable management, 31
- CMOS RAM
 - clearing, 94
 - definition, 71
 - POST error messages, 97
 - resetting, 94
- core logic chipset
 - south bridge, 106
- CSR. *See* customer self repair

Customer Self Repair, 5

D

- diagnostics
 - Array Diagnostic Utility, 69
 - HP Insight Diagnostics, 68
 - HP Instant Support Enterprise Edition, 69
 - Open Services Event Manager, 70
 - Phoenix SecureCore, 70
 - Survey Utility, 69
 - Web-Based Enterprise Service, 69
- drive bay configuration
 - data cable management, 35
 - hard drives, 40
 - power cable connections, 36
 - removable media drives, 37
 - system drive bays, 34
- drive release latch, 17

E

- electrostatic discharge, 29
- embedded NIC port
 - location, 100
 - MAC address, 73
- environmental specifications
 - acoustic noise, 110
 - altitude, 110
 - relative humidity, 110
 - temperature, 110
- ESD. *See* electrostatic discharge
- expansion board
 - expansion slots, 51
 - installing, 51
- expansion slot cover
 - removing, 51
- expansion slot cover retainer
 - installing, 52
 - removing, 51
- external ambient thermal sensor
 - able connector, 102
 - location, 99

F

front bezel

- part number, 17
- removing, 33

front panel, 99

G

General Help window, 72

H

hard disk drive

- configuring, 76
- installing, 40
- part number, 21
- supported drives, 40

hard drive

- storage controller, 106

hardware configuration

- BIOS splash screen, 92
- ESD damage prevention, 29
- expansion board, 51
- memory, 49
- Phoenix SecureCore Setup Utility, 70
- post-installation procedure, 30
- power supply unit, 66
- pre-installation procedure, 29
- processor, 44
- references, 27
- symbols in equipment, 28
- system battery, 61
- system drives, 34
- system fan, 64
- tools, 27
- warnings/precautions, 27

hardware monitoring

- chipset, 106
- external ambient thermal sensor, 99
- system board LED indicators, 105

HDD. See hard disk drive

HDD EMI shield

- removing, 40

heat sink

- installing, 48
- part number, 21
- precaution, 45
- removing, 45

HP

contact information, 26

technical support, 26

I

I/O ports

- listing, 106

I/O subsystem, 106

illustrated parts catalog

- mechanical components, 16
- system components, 20

Item Specific Help panel, 72

M

MAC address, 73

management NIC port

- LED indicators, 104

mechanical components, 16

Media Access Control. See MAC address

memory

- DIMM part numbers, 21
 - DIMM slots location, 49
 - error LED indicator, 105
 - installation guidelines, 49
 - installing, 50
 - population sequence, 49
 - specifications, 107
- memory controller, 106
- multi-boot support, 91

N

network operating system. See NOS support

NOS support, 109

O

ODD. See optical disc drive

onboard controllers

- LAN, 106
- memory controller, 106
- storage controller, 106
- VGA, 106

optical disc drive

- part number, 21

P

Phoenix SecureCore

- overview, 70

Phoenix SecureCore Setup Utility

- flashing the BIOS, 95

Phoenix SecureCore Setup Utility

- admin password, 88
- Advanced menu, 75
- BIOS recovery, 94
- Boot menu, 91
- clearing the CMOS RAM, 94
- closing, 91
- CMOS RAM, 71
- General Help window, 72
- Item Specific Help panel, 72
- loading system defaults, 93
- Main menu, 73
- navigation keys, 72
- non-user-configurable field, 72
- overview, 70
- recording Setup values, 93
- running, 71
- Security menu, 88
- splash screen, 92
- user-configurable field, 72
- Phoenix SecureCore software
 - POST, 96
- PhoenixBIOS Setup Utility
 - "Run Setup" message, 71
- physical specifications
 - server, 110
 - system board, 110
- POST. See Power On Self Test
- power fluctuations, caution, 30
- Power On Self Test
 - overview, 96
 - running, 96
- power supply unit
 - cable connections, 36
 - installing, 67
 - part number, 22
 - removing, 66
 - replacement warnings, 66
- power-down procedures, 30
- Power-On-Self-Test
 - error indicators, 96
 - errors messages, 96
 - non-critical errors, 96
 - troubleshooting, 98
- Preboot Execution Environment, 91
- processor
 - ATX power connector, 101

- configuring, 75
- installation guidelines, 44
- installing, 47
- part numbers, 21
- removing, 46
- socket location, 44
- technical specifications, 107
- thermal compound, 46
- PSU. See power supply unit
 - specifications, 108
- PXE. See Preboot Execution Environment

R

- rear panel, 100
- recording Setup values
 - CMOS backup utility, 93
 - manual record, 93
- removable media drive
 - installing, 37
 - supported drives, 37
- removable media drive bay EMI shield
 - removing, 38

S

- SAS cache battery
 - installing, 55
 - part number, 21
- SAS cache board, 53
- SAS controller board
 - installing, 54
 - part number, 21
- SAS hard drive
 - cable connections, 35
 - installing, 40
- SAS HDD cable
 - connection, 35
 - part number, 21
- SAS LED cable
 - connection, 35
 - part number, 21
- SATA hard drive
 - cable connections, 35
 - data cable connectors, 101
 - installing, 40
- SATA HDD cable
 - connections, 35
- SATA ODD cable

- connections, 35
- server management
 - configuring, 76
 - specification, 107
 - status LED indicators, 104
- software specifications
 - NOS, 109
 - system diagnostics, 109
- spare parts
 - mechanical components, 16
 - storing, 29
 - system components, 20
 - transporting, 29
- standby mode
 - activating, 30
 - effects, 30
 - system board LED indicator, 105
- status LED indicators
 - hard drive activity, 104
 - LAN activity, 104
 - system board, 105
- system board
 - ATX power connector, 101
 - dimensions, 110
 - layout, 101
 - part number, 21
 - platform, 110
 - status LED indicators, 105
- system components, 20
 - front panel, 99
 - rear panel, 100
 - system board, 101
- system covers
 - access panel, 32
 - front bezel, 33

- system date
 - POST error message, 97
 - setting, 73
- system fan
 - error LED indicator, 105
 - part number, 21
 - replacement warning, 64
 - replacing, 64
- system time
 - POST error message, 97
 - setting, 73

T

- technical specifications
 - environmental, 110
 - hardware, 106
 - memory, 107
 - physical, 110
 - power supply unit, 108
 - processor, 107
 - software, 109
- thermal compound, 46
- thermal solution, 107
- TPM. See Trusted Platform Module
- Trusted Platform Module, 102

U

- uATX
 - Micro Advanced Technology Extended. See system board, platform
- uninterruptible power supply, 30
- UPS. See uninterruptible power supply

V

- VGA controller, 106

W

- warranty, 5